



B 5232-1/-2: Assembly Kit / H51q-H/HR: System

System H51q-H/HR in K 1412B system subrack, 5 HU, 19 inches with redundant central module, power supply 24/5 V, power supply monitoring module, I/O bus connection, communication modules (optional), coprocessor modules (optional) and three fans

H51q-H / B 5232-1: single channel bus, redundant central modules

H51q-HR / B 5232-2: redundant bus, redundant central modules

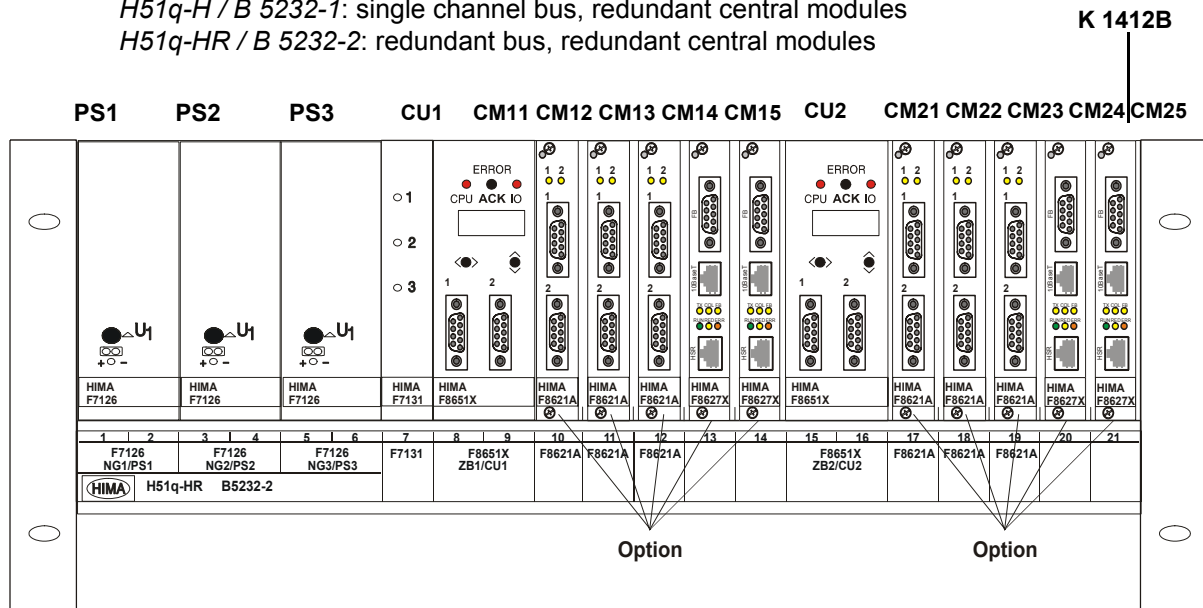

Figure 1: Front view

1 Parts of the B 5232-1/-2 assembly kit / H51q-H/H51q-HR system

- 1 x K 1412B central rack, 5 units high, 19 inches, with cable tray with three fan modules K 9212, hinged receptacle for the label and backplane Z 1001.
- additional modules on the rear
 - 3 x Z 6011 decoupling and fusing to feed the power supply modules
 - 1 x Z 6018 fan run monitoring and fuse monitoring
 - 2 x Z 6013 decoupling and fusing of the supply voltage for the WD signal
 - 2 x F 7546 bus termination module (B 5232-1)
 - 4 x F 7546 bus termination module (B 5232-2)
 - 1 x BV 7032 data cable (only B 5232-1)

includes the modules:

- 3 x F 7126 power supply modules 24 V / 5 V, 10 A (PS1, PS2, PS 3)
- 1 x F 7131 power supply monitoring
- 2 x F 8651X central module (CU1, CU2)

modules for option (separate order)

- 6 x F 8621A coprocessor modules (CM11 - CM13, CM21 - CM23)
- 10 x communication modules (CM11 - CM15, CM21 - CM25)

Assembly kits to be used for the I/O level:

- B 9302 I/O subrack 4 units high, 19 inches
- B 9361 additional power supply, 5 VDC, 5 units high, 19 inches

The max. current must be 18 A (all I/O modules and the modules in the central rack), if 3 x F 7126 are used to keep the system in operation even one power supply module F 7126 has failed.

Values of the current requirement (+5 VDC) refer to the data sheets.

Note

Operating system/resource type in ELOP II

The assembly kit is usable since operating system BS41q/51q V7.0-8.
Resource type in ELOP II: H51qe-H/H51qe-HR.

2 Modules

2.1 Central module F 8651X

The central module of the PES H51q-H/HR contains the essential functions demonstrated in the block diagram of the central module:

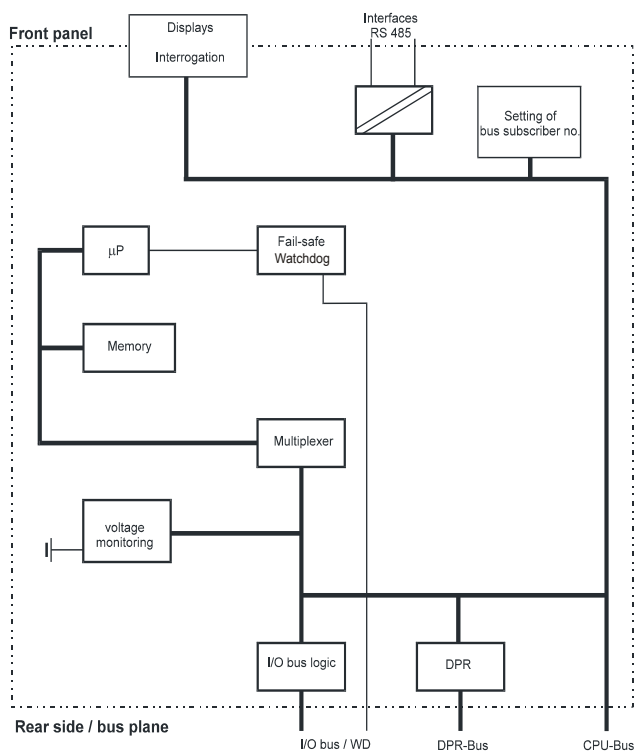

Figure 2: Block diagram of the central module F 8651X

- Microprocessor
- Flash-EPROMs of the program memory for the operating system and the user program usable for min. 100,000 writing cycles
- Data memory in sRAM
- Dual Port RAM for fast memory access to the second central module
- 2 interfaces RS 485 with galvanic isolation. Transmission rate: max. 57600 bps
- 4digit diagnostic display and 2 LEDs for information out of the system, I/O level and user program
- Power supply monitoring

- I/O bus logic for the connection to the input/output modules
- Hardware clock, battery buffered
- Watchdog
- Battery backup of the sRAMs via batteries on the central module with monitoring

2.2 Coprocessor module F 8621A

Right of each installed central module of the H51q-H/HR PES up to three coprocessor modules can be installed. The coprocessor module mainly contains:

- Microprocessor HD 64180 with a clock frequency of 10 MHz
- Operating system EPROM
- RAM for a PLC master project

Note	The RAM for the master project is buffered via the batteries on the power supply monitoring module F 7131.
-------------	--

- Two interfaces RS 485, via communication software function block setting of the baud rate up to 57600 bps
- Dual port RAM (DPR) for the communication with the central module via CPU bus

2.3 Communication modules F 8627/F 8628, F 8627X/F 8628X

Right of each installed central module of the H51q-H/HR PES up to five communication modules can be installed. The communication module mainly contains:

- 32-bit RISC microprocessor
- Operating system
- RAM for further protocols
- F 8627 Ethernet interface (safeethernet, OPC, ...)
- F 8628 Profibus-DP slave interface
- Dual port RAM (DPR) for the communication with the central module via CPU bus

Special applications with the communication module F 8627X:

- connection of the central module to a PADT (ELOP II TCP)
- connection to other communication partners within an Ethernet network (Modbus TCP)

Special application with the communication module F 8628X:

- ELOP II TCP connection (PADT) via the Ethernet interface of the F 8628X to the H41q/H51q controller

3 Startup and maintenance

A battery change of the buffer batteries on the power supply monitoring module and the central module (CPU in operation) is recommended every 6 years.

Buffer battery with soldering lug: HIMA part no. 44 0000016.

Buffer battery without soldering lug: HIMA part no. 44 0000019.

Further informations see also catalog H41q/H51q, chapter 9, "Startup and maintenance".

4 Wiring of the assembly kit

The assembly kit is already wired for operation. Wirings have still to be done by the user (optional modules, see "Assembly kit, wiring diagram").



With installation of the assembly kit a conductive connection to the frame or a separate earth connection has to be installed according to the EMC requirements.

Connection PE earth: Faston 6.3 x 0.8 mm.

Pay attention for the manufacturers information concerning detaching and replugging of the Faston connectors!

4.1 Current distribution within the assembly kit

4.1.1 HIMA devices for current distribution

It is recommended to use the HIMA supplies and current distributions:

- K 7212** redundant feeding up to 35 A total current, with 2 decoupling diodes and 2 network filters, with fusing of up to 12 single circuits with circuit breakers or
- K 7213** redundant feeding up to 35 A total current, with fusing of up to 12 single circuits with circuit breakers or
- K 7214** redundant feeding up to 150 A total current, with fusing of up to 18 single circuits with circuit breakers or
- K 7215** redundant feeding up to 150 A total current, with fusing of up to 18 single circuits with circuit breakers, graphical display.

4.1.2 Supply 24 VDC

The 24 VDC power supply can be feeded three times to the system H51q-H/HR (starlike wiring). See also catalog H41q/H51q, chapter 4.3, The Input/Output Level, 24 VDC Supply and Distribution.

Connection	Wire and connection	Fusing	Use
XG.21/22/23:2 (L+)	RD 2.5 mm ² , Faston 6.3 x 0.8	max. 16 A gL	PS1...PS3
XG.21/22/23:1 (L-)	BK 2.5 mm ² , Faston 6.3 x 0.8		Reference pole L-
RD = Color code red		BK = Color code black	

Table 1: Supply 24 VDC

4.1.3 Output 24 VDC

Connection	Wire and connection	Use
XG.24:2 (L+)	RD 1.5 mm ² , Faston 6.3 x 0.8	Supply fuse monitoring and IO-CON in the I/O rack
XG.25:2 (L+)	RD 1.5 mm ² , Faston 6.3 x 0.8	Supply fuse monitoring and IO-CON in the I/O rack for 2nd I/O bus only B 5232-2)
RD = Color code red		

Table 2: Output 24 VDC

4.1.4 Supply 5 VDC

The 5 VDC power supply does not have to be wired extra as it is already part of the installation. To supply the I/O racks the 5 V power supply with corresponding GND is available at the rear side of the central rack.

The 5 VDC power and GND are connected starlike with each 2 wires to the potential distributor. The 5 VDC power needed for the microprocessor system and as control current for the I/O modules is generated from the 24 VDC power of the system via (24 VDC / 5 VDC) power supply modules type F 7126. One central rack can be equipped with a maximum of 3 power supply modules. The power supply modules are switched in parallel. One or two power supply modules are usually able to supply the PES. A further power supply module is used to increase availability.

Note At planning the load of the power supply units have to be calculated.

The 5 VDC output voltage of the power supply module (for the CPU, I/O and the interfaces) are monitored by the power supply monitoring module F 7131 checking undervoltage, overvoltage or failure.

In case of a faulty power supply module the operating system of the CPU informs the user program via a system variable.

In case of a 5 VDC system power failure a lithium battery on the central module buffers the hardware clock and sRAM on the central module.

The sRAM memory of the coprocessor module is buffered via two lithium batteries on the power supply monitoring module F 7131.

4.1.5 Output 5 VDC

Connection	Wire and connection	Use
XG.2: +5 V	YE 2 x 2.5 mm ² , Faston 6.3 x 0.8	Supply I/O subrack (B 9302)
XG.3: GND	GN 2 x 2.5 mm ² , Faston 6.3 x 0.8	Supply I/O subrack (B 9302)
GN = Color code green		YE = Color code yellow

Table 3: Output 5 VDC

4.2 Output WD

Connection	Wire and connection	Use
XG.1:2 (4) and XG.1:6 (8)	GY 0.5 mm ² , wire end ferrule	WD to I/O subrack (only B 5232-1)
GY = Color code gray		

Table 4: Output WD

4.3 Connection of the monitoring loop (for fuses and fans)

Connection	Wire and connection	Fusing	Use
XG.26:4/5/6	GY 0.5 mm ² , Faston 2.8 x 0.8	max. 4 A slow blow	Floating NO/NC contact for signaling
GY = Color code gray			

Table 5: Connection of the monitoring loop

4.4 Internal fuses

Position	Size	Dimension	HIMA part no.
Z 6011	4 A slow blow	5 x 20 mm	57 0174409
Z 6013	1.6 A slow blow	5 x 20 mm	57 0174169

Table 6: Internal fuses

4.5 I/O bus

The data connection of the I/O level with the central module is established via the I/O bus.

4.5.1 System H51q-H

The data cable BV 7032 connects the I/O buses of central module 1 (XD.2) to central module 2 (XD.1).

I/O bus, H51q-H / B 5232-1

Connection	Procedure
XD.1 to XD.2	Connect with cable BV 7032
XD.4	Remove bus termination module F 7546 and plug it on XD.2 of the last I/O rack, then connect cable BV 7032 from XD.1 of the 1st I/O rack to empty terminal XD.4

Table 7: I/O bus, H51q-H / B 5232-1

4.5.2 System H51q-HR

The system H51q-HR has a redundant I/O bus. Each of the central modules has its own I/O bus and therefore only the correlated I/O subracks. The 1st I/O bus is assigned to central module 1 and the 2nd I/O bus is assigned to central module 2.

I/O bus, H51q-HR / B 5232-2

Connection	Procedure
XD.3 and XD.4	Remove bus termination module F 7546 and plug it on XD.2 of the last I/O rack of both I/O buses
XD.4	Plug in cable BV 7032 of the 1st I/O rack to the 1st I/O bus
XD.3	Plug in cable BV 7032 of the 2nd I/O rack to the 2nd I/O bus

Table 8: I/O bus, H51q-HR / B 5232-2

4.5.3 Systems H51q-H/HR

For the I/O rack the connection to the I/O bus is made via a coupling module F 7553 installed in slot 17. The connection of the bus between the individual subracks is established at the rear side via the BV 7032 data cable.

To terminate the I/O bus, an F 7546 module is plugged in at the beginning on central subrack and at the end (last I/O rack).

4.5.4 Construction principle of the I/O bus of the system H51q-H

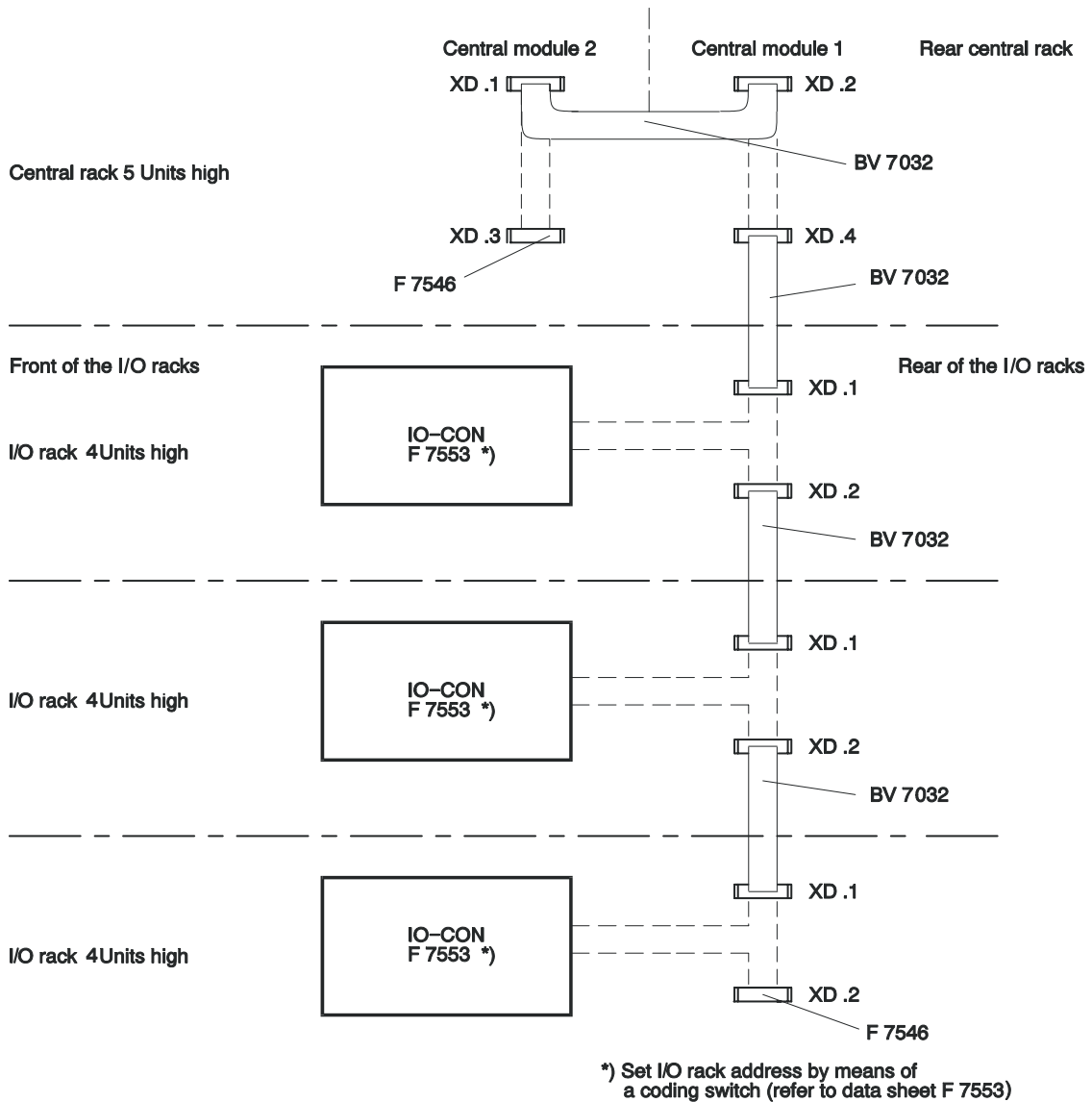

Figure 3: Construction principle of the I/O bus for system H51q-H

max. length I/O bus:	12 m
max. length cable BV 7032:	5 m
cable BV 7032 between subracks:	max. 0.5 m

4.5.5 Construction principle of the I/O bus of the system H51q-HR

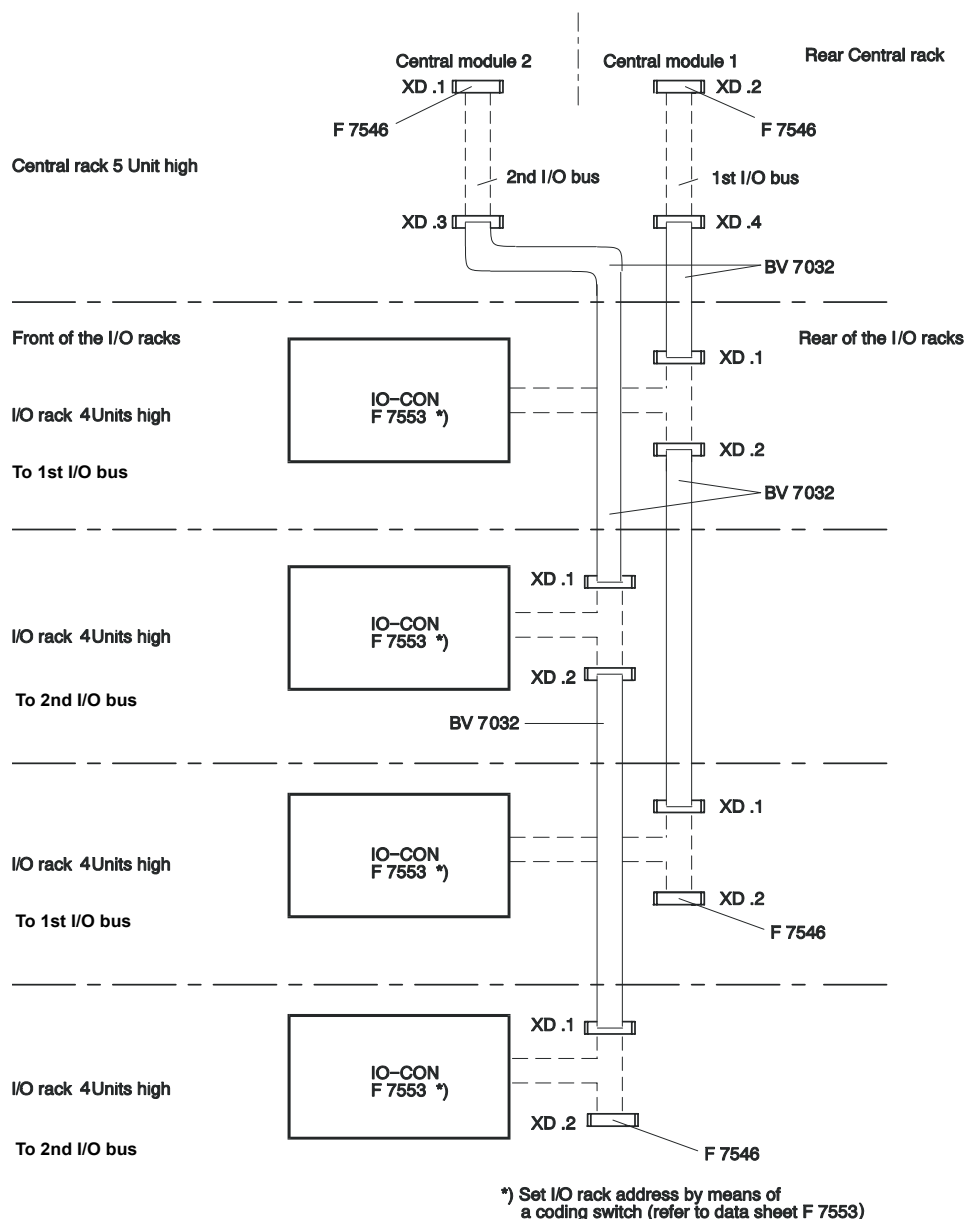

Figure 4: Construction principle of the I/O bus for system H51q-HR

max. length I/O bus:	12 m
max. length cable BV 7032:	5 m
cable BV 7032 between subracks:	max. 0.5 m

4.6 Connections on the rear

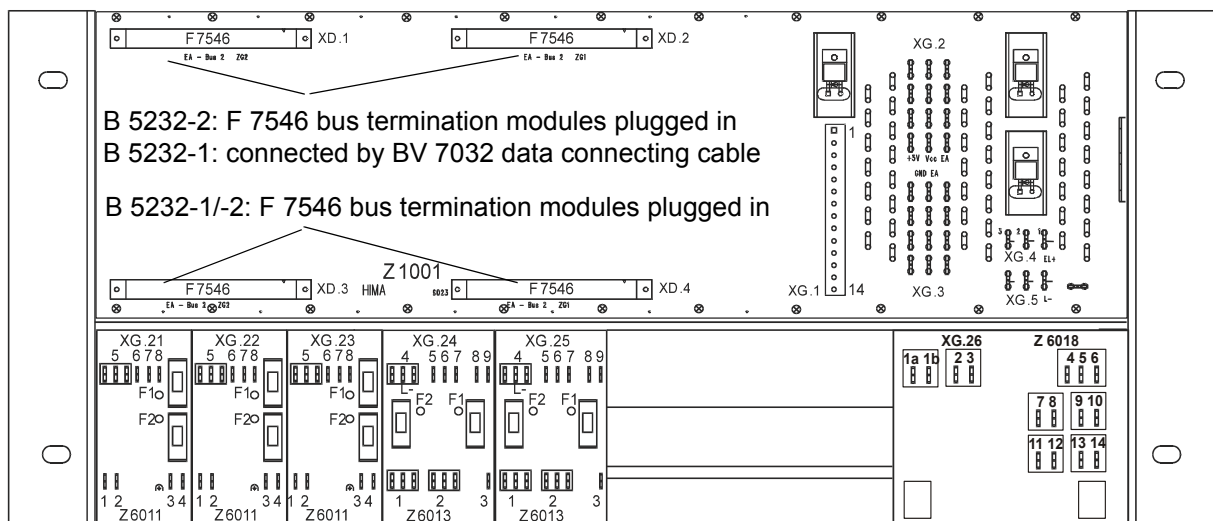

Figure 5: Connections on the rear of the system rack K 1412B

4.6.1 Wiring ex works

XD.1, XD.2	B 5232-2: Bus termination module F 7546 plugged B 5232-1: BV 7032 data connecting cable plugged
XD.3, XD.4	B 5232-1/-2: Bus termination module F 7546 plugged
XG.1: 1, 3	Watchdog supply for module Z 6013
XG.1: 5, 7	Watchdog supply for module Z 6013
XG.1: 12 - 13	Connection external buffer battery on module F 7131
XG.1: 14	Ground (GND) for connection external buffer battery
XG.4	L+ for power supply 24V
XG.5	Reference potential: (L-)

Connections of the additional modules (see assembly kit, wiring diagram)

XG.24, XG.25	Z 6013
XG.26	Z 6018

4.6.2 Wiring by customer

XG.1: 2, 4	Watchdog signal for I/O modules
XG.1: 9 - 11	Monitoring power supplies PS1 - PS3 by F7131 for external examination
XG.2	Connection 5 VDC for I/O subrack
XG.3	Ground (GND) for supply 5 VDC
XG.21, XG.22, XG.23	Supply 24 V via module Z 6011 (see assembly kit, wiring diagram) L+, L-

4.7 Assembly kit, wiring diagram

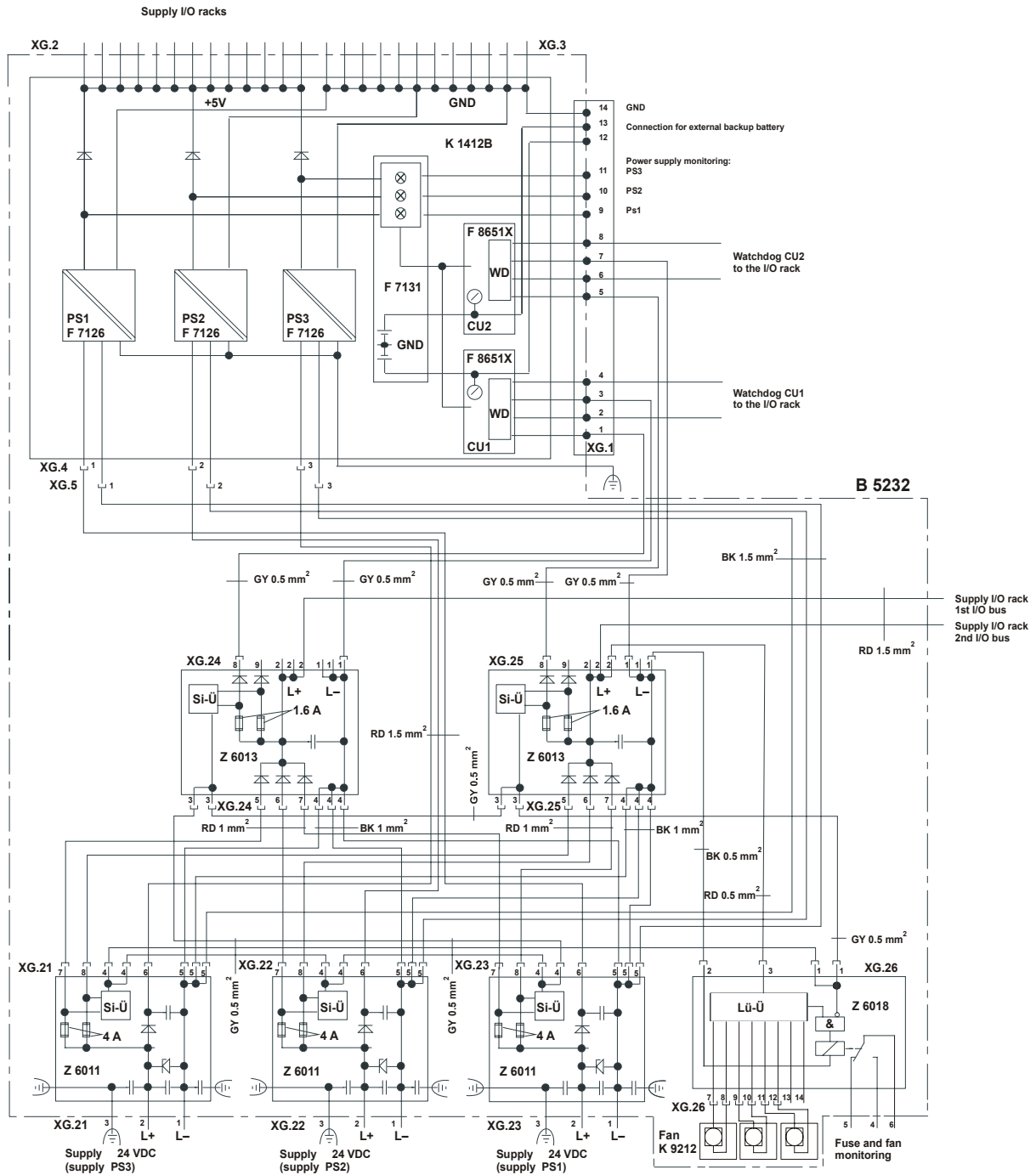

Figure 6: Assembly kit, wiring diagram

Lü-Ü = Fan monitoring
Si-Ü = Fuse monitoring

5 Side view B 5232-1/-2 assembly kit / H51q-H/HR system

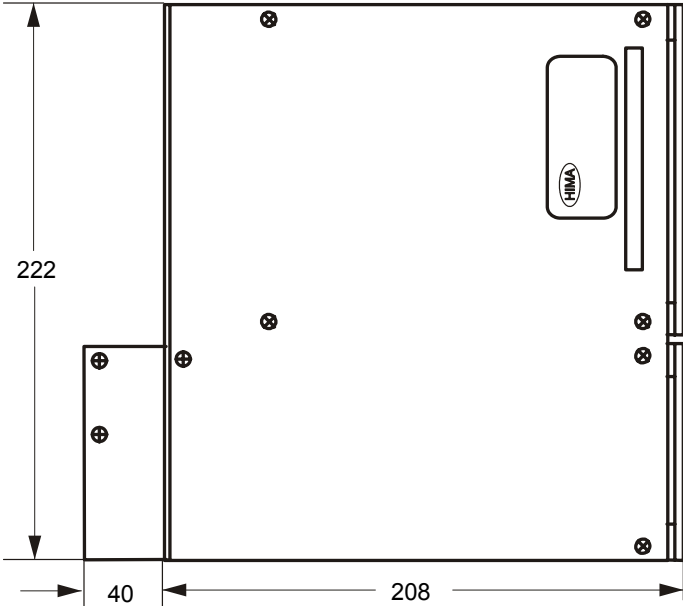

Figure 7: Side view

