



B 4234: Assembly Kit / H41q-M: System

System H41q-M in K 1409 system subrack, 5 HU, 19 inches with single channel central module, power supply 24/5 V, I/O level, communication module (optional), coprocessor module (optional) and four fans

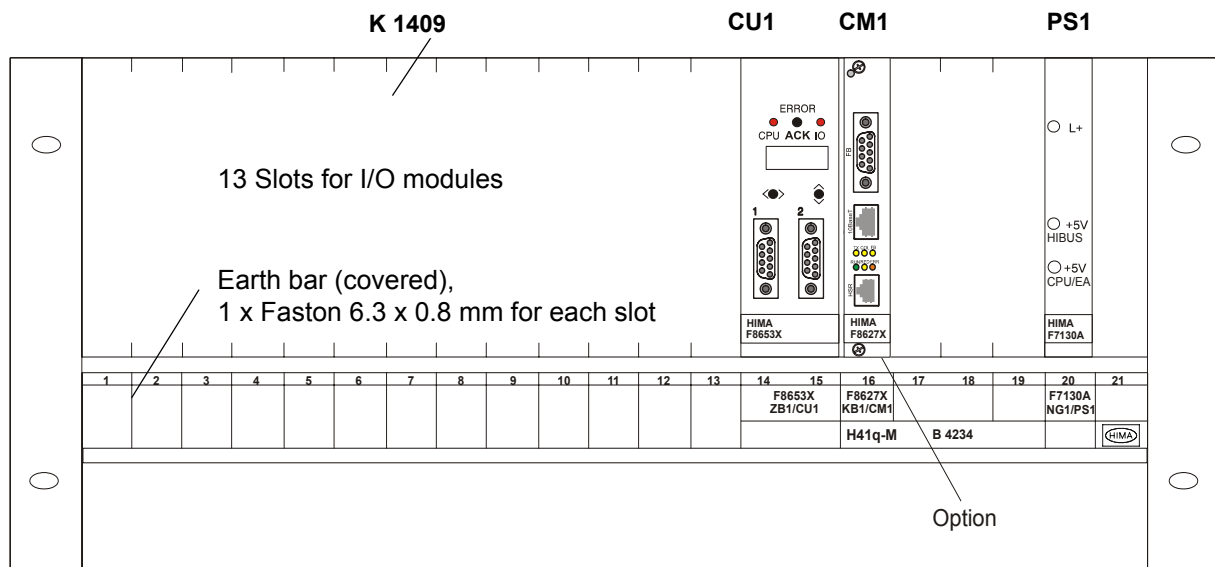

Figure 1: Front view

1 Parts of the B 4234 assembly kit / H41q-M system

- 1 x K 1409 system subrack, 5 HU, 19 inch, with cable tray with four fan modules K 9212, hinged receptacle for the label and backplane Z 1009. On the rear buffer batteries (G1, G2).
- additional modules on the rear
 - 2 x Z 6011 decoupling and fusing to feed the power supply modules
 - 1 x Z 6018 fan run monitoring and fuse monitoring
 - 2 x Z 6013 decoupling and fusing for the supply voltage of the WD signal
 - 1 x Z 6007 jumper plug (combination of the separated I/O buses, single channel system H41q-M)

include the modules:

- 1 x F 8653X central module (CU1)
- 1 x F 7130A power supply 24/5 VDC (PS1)

Modules for option (separate order):

- 1 x F 8621A coprocessor module (CU1)
- 1 x communication module (CM1), e.g. F 8627X (Ethernet) or F 8628X (Profibus DP)
- max.13 I/O modules (slots1 to 13)
- 1 x F 7130A power supply 24/5 V on slot 21

Note **Operating system/resource type in ELOP II**
The assembly kit is usable since operating system BS41q/51q V7.0-8.
Resource type in ELOP II: H41qce-M.

2 Modules

2.1 Central module F 8653X

The central module of the PES H41q-M contains the essential functions demonstrated in the block diagram of the central module:

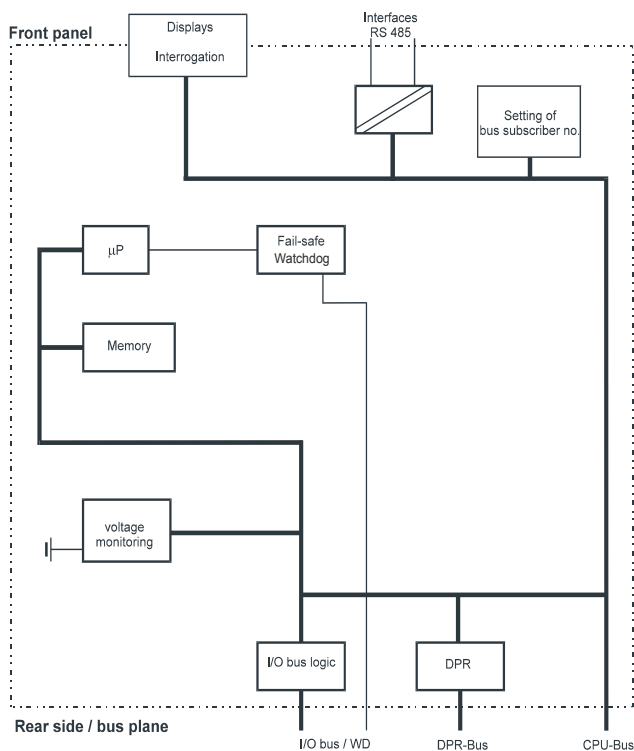

Figure 2: Block diagram of the central module F 8653X

- Microprocessor
- Flash-EPROMs of the program memory for the operating system and the user program usable for min. 100,000 writing cycles
- Data memory in sRAM
- 2 interfaces RS 485 with galvanic isolation. Transmission rate: max. 57600 bps
- 4digit diagnostic display and 2 LEDs for information out of the system, I/O level and user program
- Power supply monitoring
- I/O bus logic for the connection to the input/output modules
- Hardware clock, battery buffered
- Watchdog
- Battery backup of the sRAMs via battery with monitoring

2.2 Coprocessor module F 8621A

Right of the central module of the H41q-M PES one coprocessor module can be installed. The coprocessor module mainly contains:

- Microprocessor HD 64180 with a clock frequency of 10 MHz
- Operating system EPROM
- RAM for a PLC master project

Note	The RAM for the master project is buffered via the batteries on the backplane of the subrack.
-------------	---

- Two interfaces RS 485, via communication software function block setting of the baud rate up to 57600 bps
- Dual port RAM (DPR) for the communication with the central module via CPU bus

2.3 Communication modules F 8627/F 8628, F 8627X/F 8628X

Right of the central module of the H41q-M PES one communication module can be installed. The communication module mainly contains:

- 32-bit RISC microprocessor
- Operating system
- RAM for further protocols
- F 8627 Ethernet interface (safeethernet, OPC, ...)
- F 8628 Profibus-DP slave interface
- Dual port RAM (DPR) for the communication with the central module via CPU bus

Special applications with the communication module F 8627X:

- connection of the central module to a PADT (ELOP II TCP)
- connection to other communication partners within an Ethernet network (Modbus TCP)

Special application with the communication module F 8628X:

- ELOP II TCP connection (PADT) via the Ethernet interface of the F 8628X to the H41q/H51q controller

3 Startup and maintenance



Before startup the system switch on the rear buffer batteries G1 and G2 via DIP switches on the backplane!

A battery change of the buffer batteries without load (CPU in operation) is recommended every 6 years.

Buffer battery with soldering lug: HIMA part no. 44 0000016.

Buffer battery without soldering lug: HIMA part no. 44 0000019.

Further informations see also catalog H41q/H51q, chapter 9, "Startup and maintenance".

4 Wiring of the assembly kit

The assembly kit is already wired for operation. Wirings have still to be done by the user (optional modules, see "Assembly kit, wiring diagram").



With installation of the assembly kit a conductive connection to the frame or a separate earth connection has to be installed according to the EMC requirements.

Connection PE earth: Faston 6.3 x 0.8 mm.

Pay attention for the manufacturers information concerning detaching and replugging of the Faston connectors!

4.1 Current distribution within the assembly kit

4.1.1 HIMA devices for current distribution

It is recommended to use the HIMA supplies and current distributions:

- K 7212** redundant feeding up to 35 A total current, with 2 decoupling diodes and 2 network filters, with fusing of up to 12 single circuits with circuit breakers or
- K 7213** redundant feeding up to 35 A total current, with fusing of up to 12 single circuits with circuit breakers or
- K 7214** redundant feeding up to 150 A total current, with fusing of up to 18 single circuits with circuit breakers or
- K 7215** redundant feeding up to 150 A total current, with fusing of up to 18 single circuits with circuit breakers, graphical display.

4.1.2 Supply 24 VDC

See also catalog H41q/H51q, chapter 3.3, The Input/Output Level, 24 VDC Supply and Distribution.

Connection	Wire and connection	Fusing	Use
XG.24:2 (L+)	RD 2.5 mm ² , Faston 6.3 x 0.8	max. 16 A	PS1
XG.24:1(L-)	BK 2.5 mm ² , Faston 6.3 x 0.8		Reference pole L-
XG.14 (L-)	BK 2 x 2.5 mm ² , Faston 6.3 x 0.8 (see note)		Reference pole L-
XG.6 (L+)	RD 1 mm ² , Faston 2.8 x 0.8 13 single connections	max. 4 A slow blow	see wiring diagram
RD = Color code red BK = Color code black			

Table 1: Supply 24 VDC



Connection XG.14: To be wired to the central L- bus bar with at least 2 x 2.5 mm² BK. If output modules with 2-pole connection to the actors are used depending on the load up to 4 x 2.5 mm² BK wiring is necessary.

4.1.3 Supply 5 VDC

The 5 VDC power supply does not have to be wired separately as it is already installed as part of the subrack.

The 5 VDC power is used for the CPU, the control of the interfaces and the I/O modules. It is generated by 24 VDC / 5 VDC power supply module type F 7130A.

The 5 VDC output voltage of the power supply module (for the CPU, I/O and the interfaces) are monitored on the central module checking undervoltage, overvoltage or failure.

In case of a faulty power supply module the operating system of the CPU informs the user program via a system variable.

In case of a 5 VDC system power failure a lithium battery on the central module buffers the hardware clock and sRAM on the central module.

4.2 Connection of the monitoring loop (for fuses and fans)

Connection	Wire and connection	Fusing	Use
XG.21:4/5/6	GY 0.5 mm ² , Faston 2.8 x 0.8	max. 4 A slow blow	Floating NO/NC contact for signaling
GY = Color code gray			

Table 2: Connection of the monitoring loop

4.3 Internal fuses

Position	Size	Dimension	HIMA part no.
Z 6011	4 A slow blow	5 x 20 mm	57 0174409
Z 6013	1.6 A slow blow	5 x 20 mm	57 0174169

Table 3: Internal fuses

4.4 Backplane bus

Central module CU and I/O modules are connected via the backplane bus.

The jumper plug Z 6007 on connection XD .1 combines the separated I/O buses. For the single channel system this is mandatory. Redundant systems see also H41q-HR and H41q-HRS, slot 1 to 7 and 8 to13.

4.5 Connections on the rear

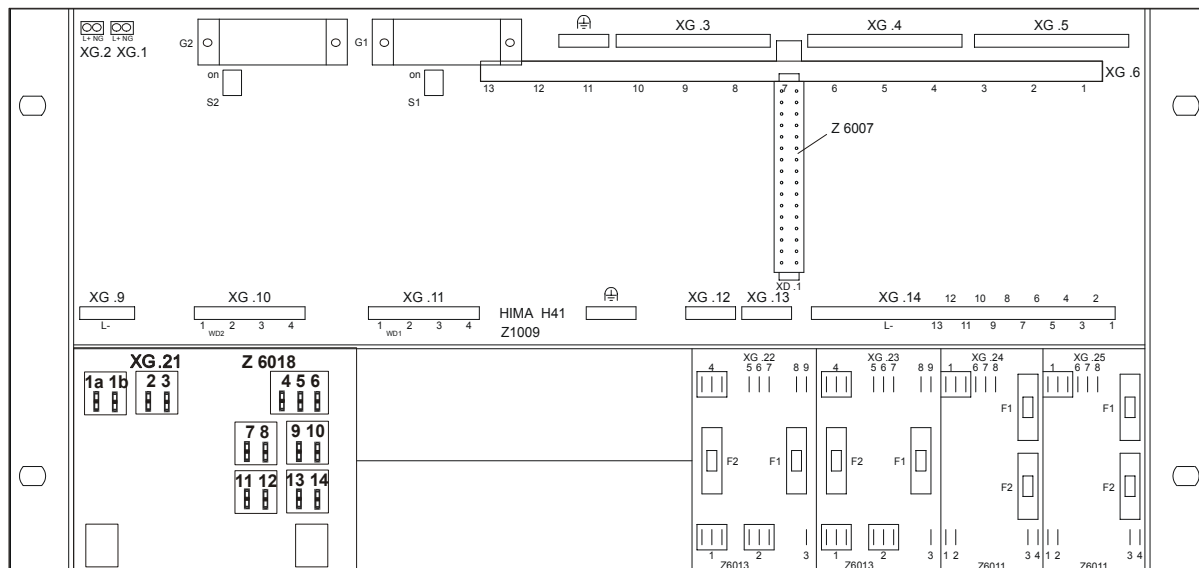

Figure 3: Connections on the rear of the system rack K 1409

4.5.1 Wiring ex works

XD .1	Jumper plug Z 6007 (combination of the separated I/O buses, single channel system H41q-M)
XG .1, XG .2	Supply L+ for the power supply module Reference pole: XG .9 (L-)
XG .3, XG .4, XG .5	Potential distributor, free disposal of
XG .9	L- for the power supply module
XG .10	Watchdog signal (not active at H41-M)
XG .11	Watchdog signal from CU1
XG .12	Watchdog signal for I/O modules (not active at H41-M)
XG .13	Watchdog signal for I/O modules



PE (earth)

Connections of the additional modules Z 6011, Z 6018, Z 6013:

XG. 21	refer to
XG. 22, XG .23	wiring of the assembly kit, wiring diagram
S1, S2	for switching off the buffer batteries G1, G2 Delivery state: Buffer batteries are switched off!

4.5.2 Wiring by customer

XG .6: 1 - 13	L+ for I/O modules (slots 1 to 13) 13 single connections, see also connection XG .14
XG .14: 1 - 13	Reference potential L- for I/O modules Slots 1 - 13, see also connection XG .6
XG .24, XG .25	Supply 24 VDC, see assembly kit, wiring diagram (L+, L-)

4.6 Assembly kit, wiring diagram

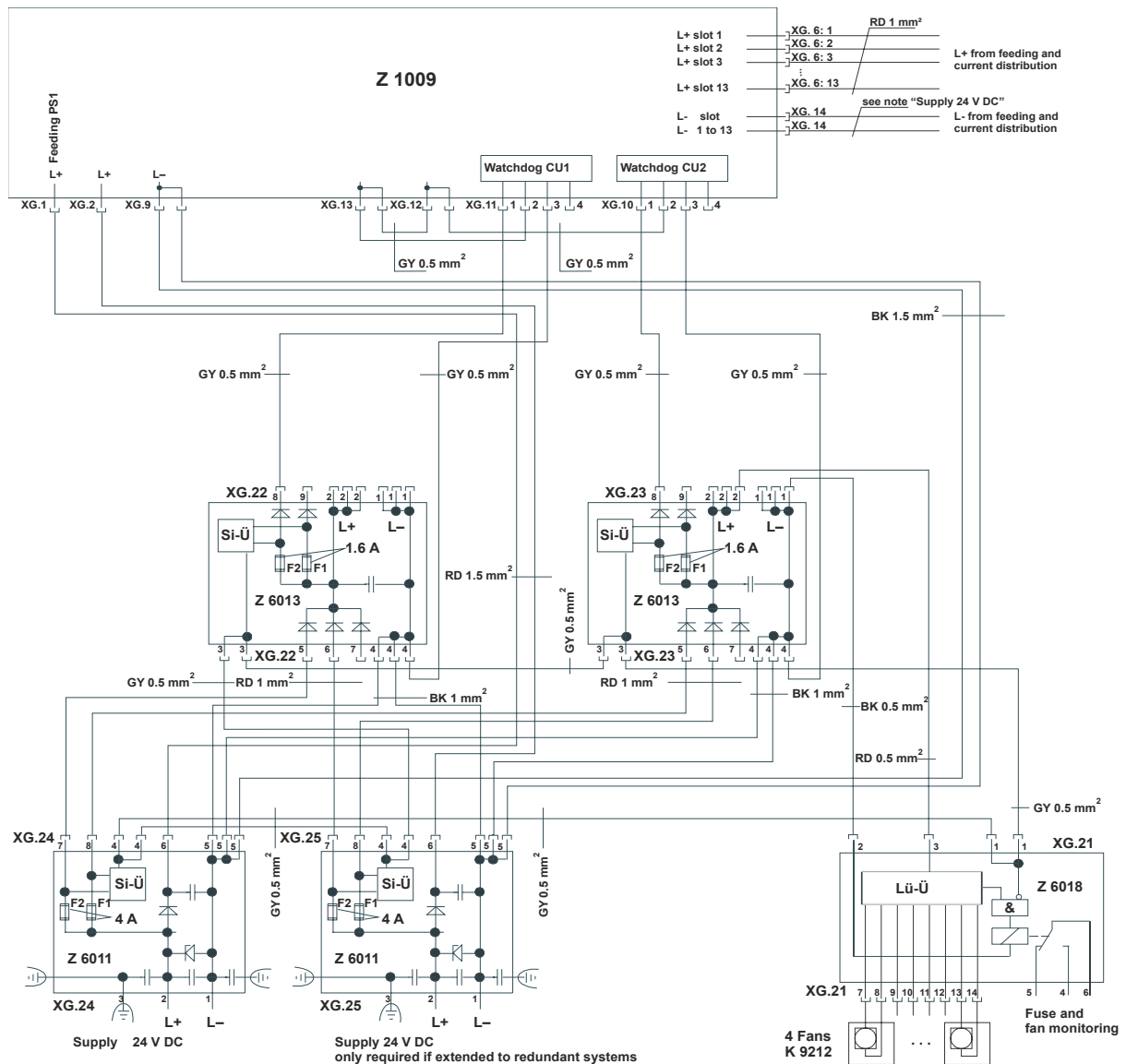

Figure 4: Assembly kit, wiring diagram

Lü-Ü = Fan monitoring
 Si-Ü = Fuse monitoring

Note

The assembly kit is fully wired for a possible extension to redundant systems. For extension to redundant I/O buses remove jumper plug Z 6007 (see data sheet H41q-HR, H41q-HRS).

5 Side view B 4234 assembly kit / H41q-M system

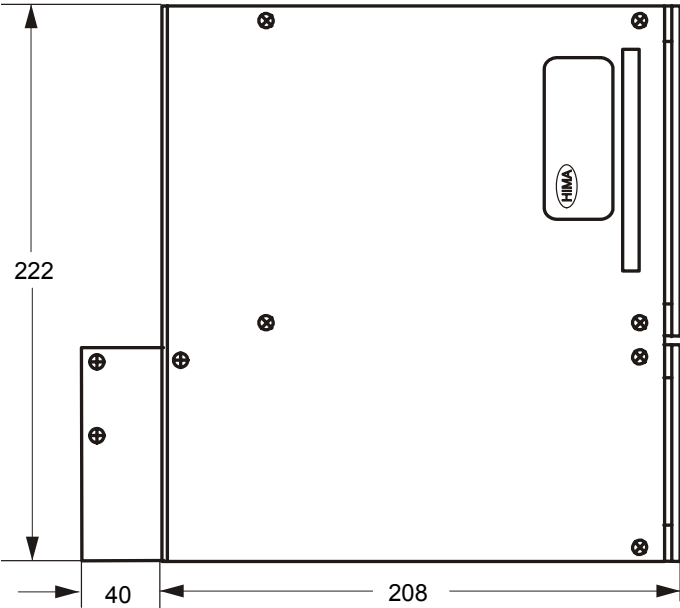

Figure 5: Side view