



F 6217: 8-channel analog input module

safety-related, applicable up to SIL 3 according to IEC 61508

- for current inputs 0/4...20 mA, voltage inputs 0...5/10 V
- with safe isolation
- resolution: 12 bits

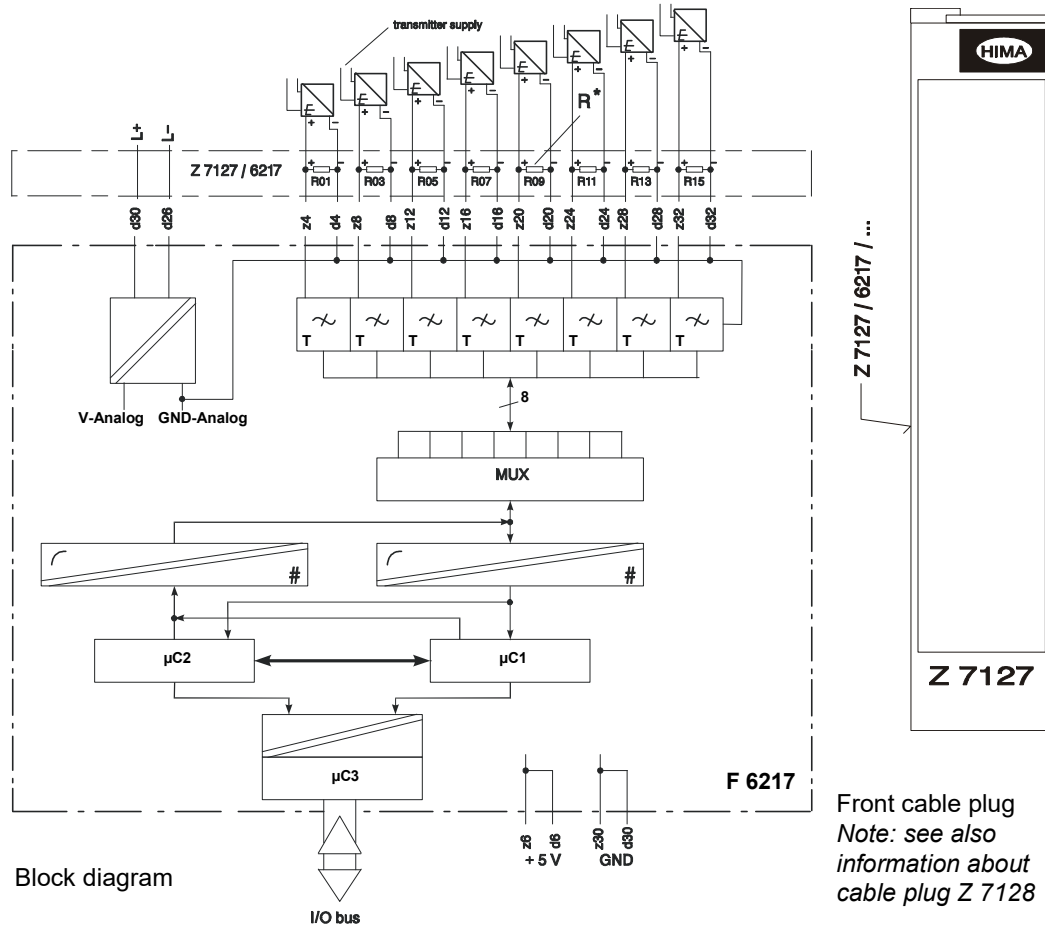

Figure 1: Block diagram and front cable plug

Interpretation of channel bit faults for each channel to project in ELOP II.

Input voltage	0...5.5 V
max. input voltage	7.5 V
Input current	0...22 mA (via shunt), 22 mA = 4095
max. input current	30 mA
R*: Shunt with	250 Ω; 0.05 %; 0.25 W;
current input	T<10 ppm/K; part-no: 00 0710251
Resolution	12 bit, 0 mV = 0, 5.5 V = 4095
Measurand update	50 ms
Safety time	< 450 ms
Input resistance	100 kΩ

F 6217 (0606)

Time const. input filter	approx. 10 ms
Basic error	0.1 % at 25 °C
Operating error	0.3 % at 0...+60 °C
Error limit related on safety	1 %
Electric strength	200 V against GND
Space requirement	4 SU
Operating data	5 VDC / 80 mA, 24 VDC / 50 mA

Channel	Connection	Color	Channel	Connection	Color
1	z4 x4 d4	BN WH	1	z4 x4 d4	BN WH
2	z8 x8 d8	YE GN	2	z8 x8 d8	YE GN
3	z12 x12 d12	PK GY	3	z12 x12 d12	PK GY
4	z16 x16 d16	RD BU	4	z16 x16 d16	RD BU
5	z20 x20 d20	VT BK	5	z20 x20 d20	VT BK
6	z24 x24 d24	WHGN WHBN	6	z24 x24 d24	WHGN WHBN
7	z28 x28 d28	WHGY WHYE	7	z28 x28 d28	WHGY WHYE
8	z32 x32 d32	WHBU WHPK	8	z32 x32 d32	WHBU WHPK
L-	d26	BK	L-	d26	BK
L+	d30	RD	L+	d30	RD
Cable screen		YEGN	Cable screen		YEGN

Cable
LiYCY
20 x 0.25 mm²
screened

l = 750 mm
q = 1 mm²

Flat pin
plug 2.8 x
0.8 mm²

l = 120 mm
q = 2.5 mm²

Flat pin plug 6.3 x 0.8 mm, to be connected to the earth bar under the slot

Lead marking cable plug to connect current/
voltage Z 7127 / 6217 / C.. / I (U5V)

Lead marking cable plug to connect voltage via
potentiometer and smart transmitters
Z 7127 / 6217 / C.. / U10V

Figure 2: Lead marking cable plug

The module contains a redundant, safety-related processor system. Because of this, all the tests are executed directly on the module. The main test routines are:

- Linearity of the A/D converters
- Overflow of the A/D converters
- Cross talking between the eight input channels
- Function of the input filters
- Function of the I/O bus communication

- Self tests of the microcontrollers
- Tests of the memories

The channel error bit is set for a recognized error; the evaluation must be made in the user program.

Current inputs

Measuring range 0/4 - 20 mA

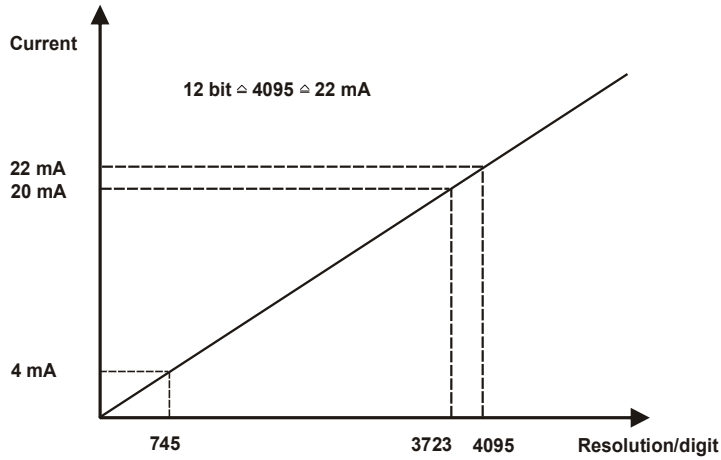

Figure 3: Current inputs

Redundant connection of current or voltage

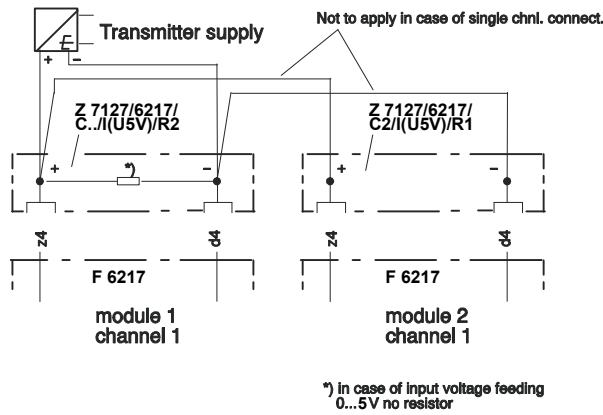

Figure 4: Redundant connection of current or voltage

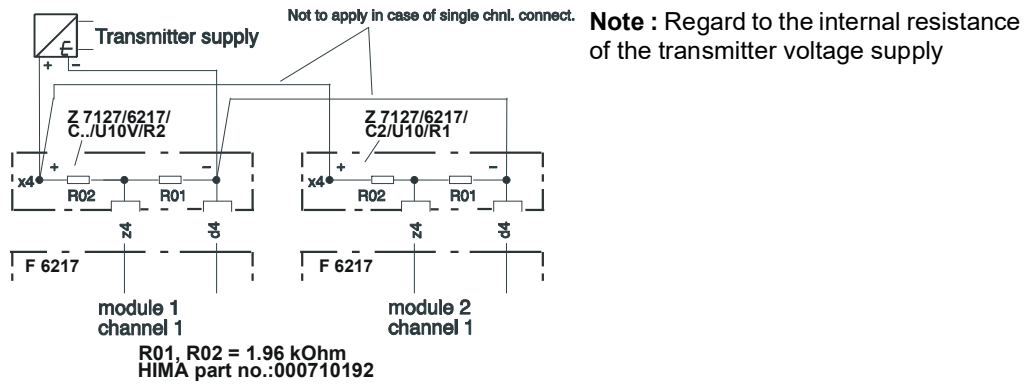

Figure 5: Redundant connection via voltage divider

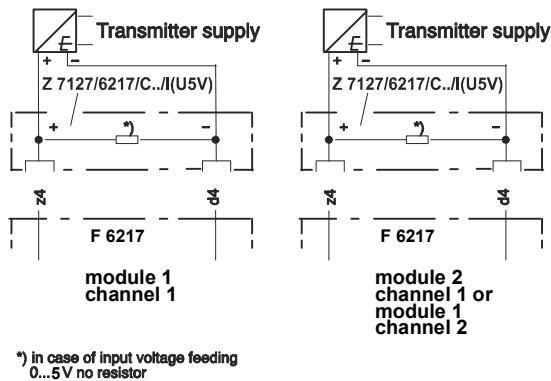

Figure 6: Current or voltage connection of redundant transmitters (evaluation in the user program)

Occupation of not used inputs

Not used voltage inputs 0 ... 5 V have to be terminated with jumpers. Not used current inputs are terminated with the shunt, not used voltage inputs 0...10 V with the voltage divider in the cable connector.

Not used inputs, redundant connection

Example is for channel 1.

Installation of jumpers outside of the cable connectors on the terminals:

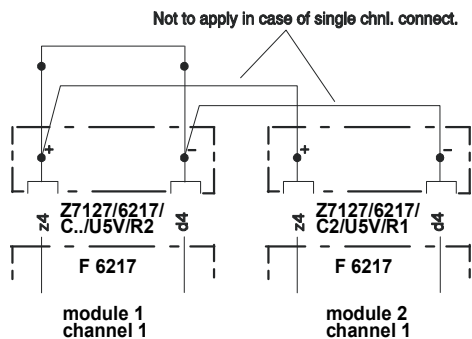

Figure 7: Voltage input 0...5 V

Notes to the safety-related operation and use

Screened cables have to be used for the field input circuits, twisted cables are recommended. If it is sure that the environment of the transmitter up to the module is free from interferences and the distance is relatively short (e. g. inside a cabinet) then the cabling can be performed without screened cables or twisted cables. However, the interference immunity of the analog inputs can only be achieved by using screened cables.

Planning notes for ELOP II

For each input channel of the module exists an analog input value and an appertaining channel fault bit. With activated channel fault bit a safety-related reaction has to be programmed in ELOP II related to the corresponding analog input.

Recommendations for the use of the module according to IEC 61508, SIL 3

- Cables for power supply shall be locally separated from the input circuits,
- Application of a suitable earthing must be regarded,
- Measures against rising of the temperature have to be taken outside of the module, e. g. fans in the cabinet,
- Recording events in a logbook for operation and maintenance.

A maintenance of the module is not required. In case of fault there is a switch-off. The failed module must be replaced.

Z 7128 Cable plug with transmitter supply

For the supply of transmitters the Z 7128 cable plug with transmitter supply is available (suitable only for two-wire connections).



This cable plug **may not be used** together with zener barriers!

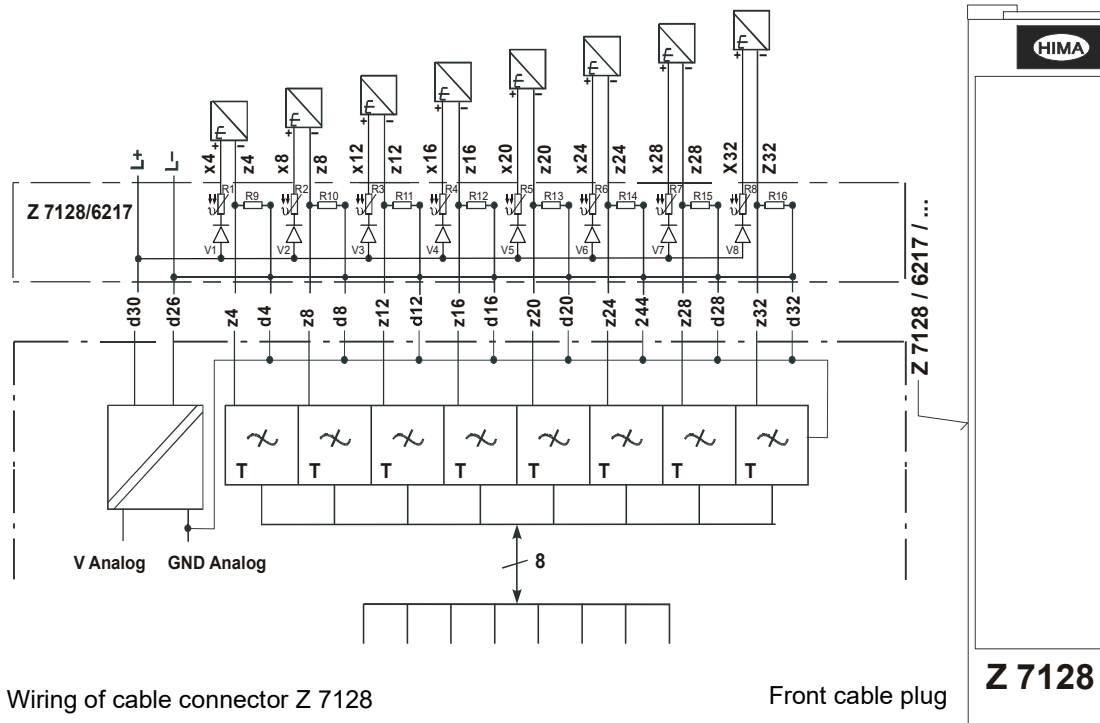
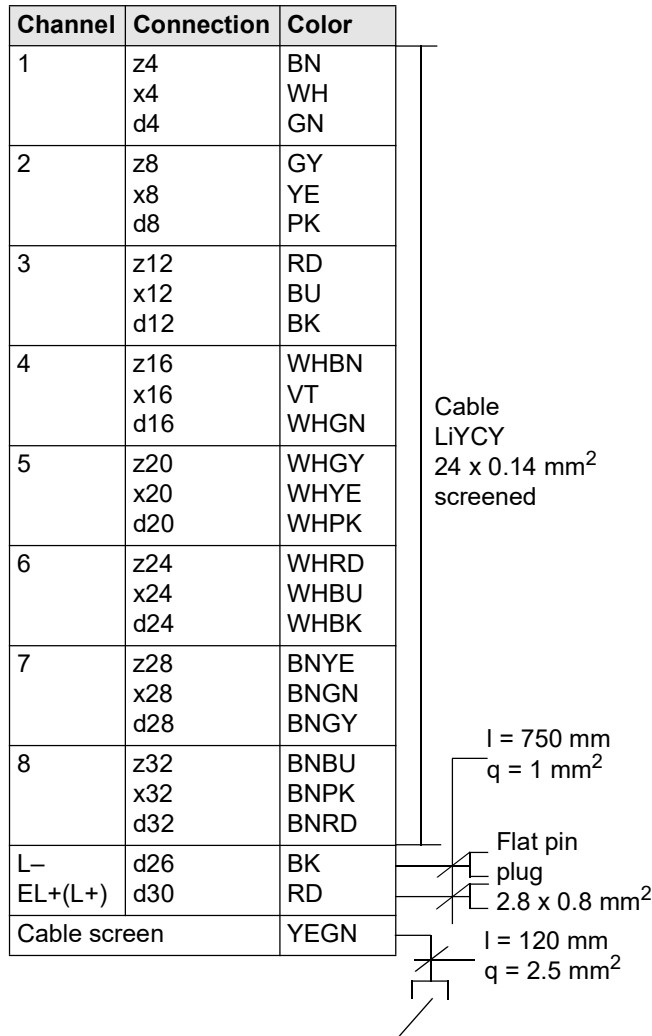

Figure 8: Wiring of cable connector Z 7128



Flat pin plug 6.3 x 0.8 mm, to be connected to the earth bar under the slot

Lead marking cable plug with transmitter supply Z 7128 / 6217 / C.. / ITI

Figure 9: Lead marking cable plug with transmitter supply

Cable plugs marked with R1 and R2 are for redundant systems, applications refer to previous figures.

If using the transmitter Saab/Rosemount 3300 GWR with internal zener diode a galvanic isolation in the signal connection must be provided to remove interferences (signal spikes, undefined signal levels) at the analog inputs of the F 6217.

Therefore e.g. the analog isolator with HART H 6200 of HIMA can be used.

Interferences of the module in low frequency range (10 Hz)

External disturbing pulses in the range of 10 Hz, e.g. at pressure measurements of nearby piston pumps, can lead to temporary channel bit faults at the analog inputs. Internal hardware tests carried out in the same rhythm are influenced by this pulses (fluctuations) in an adverse way. Input channels could be interpreted as faulty and de-energized.

Solution

- Pressure sensors:
By internal damping via adjustable digital filters in the sensor disturbing pulses can be minimized or eliminated.
- Use of low-pass filter H 7017:
The high time constant of the low-pass filter eliminates the low frequency disturbing pulses in the input current.



The low-pass filter may only be used in safety-related circuits with low-shut-down because in case of a failure in the filter (leakage current) the measured values are reduced. The time relay of the filter has to be regarded in calculating the safety time.

Note

Additional transmitter supplies, e.g. via front cable plug Z 7128, have no disturbing influences on the operation of the module F 6217.
