

Section	Page
Functional Description.....	2
Installation	2
Operation.....	5
Specifications.....	9
Diagnostics	9
Configuration	10
DTTC Simplex Thermocouple Terminal Board.....	12
Installation	13
I/O Board Alarms	14

Functional Description

Input data is transferred over the VME backplane from VTCC to the VCMI and then to the controller.

The thermocouple processor board VTCC accepts 24 type E, J, K, S (see note), or T thermocouple inputs. These inputs are wired to two barrier type blocks on the terminal board TBTC. Cables with molded plugs connect the terminal board to the VME rack where the VTCC thermocouple board is located. The TBTC can provide both simplex (TBTCH1C) or triple module redundant (TMR) (TBTCHIB) control.

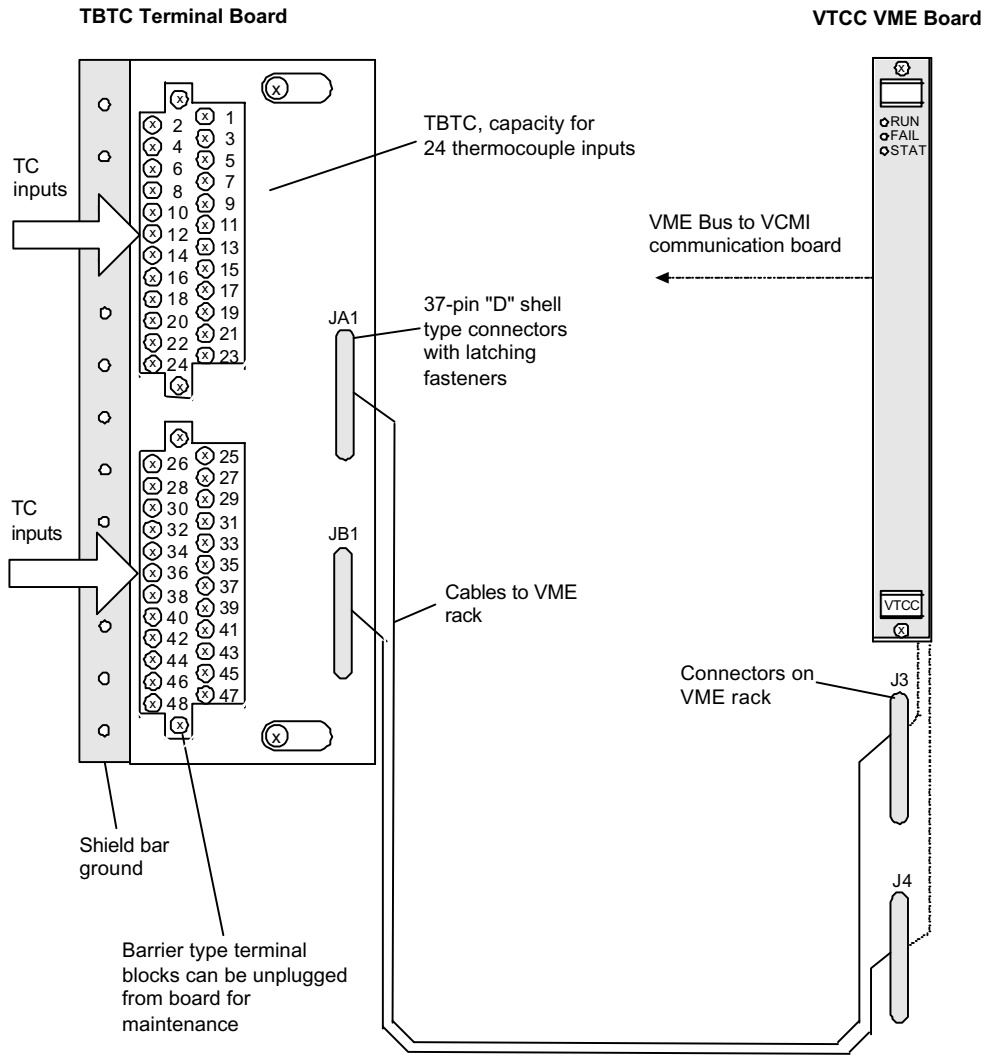

Thermocouple Input Terminal Board, I/O Board, and Cabling

Installation

Thermocouples are wired directly to two I/O terminal blocks. These blocks are mounted on the terminal board and held down with two screws. Each block has 24 terminals accepting up to two #12 AWG wires. A shield termination strip attached to chassis ground is located immediately to the left of each terminal block.

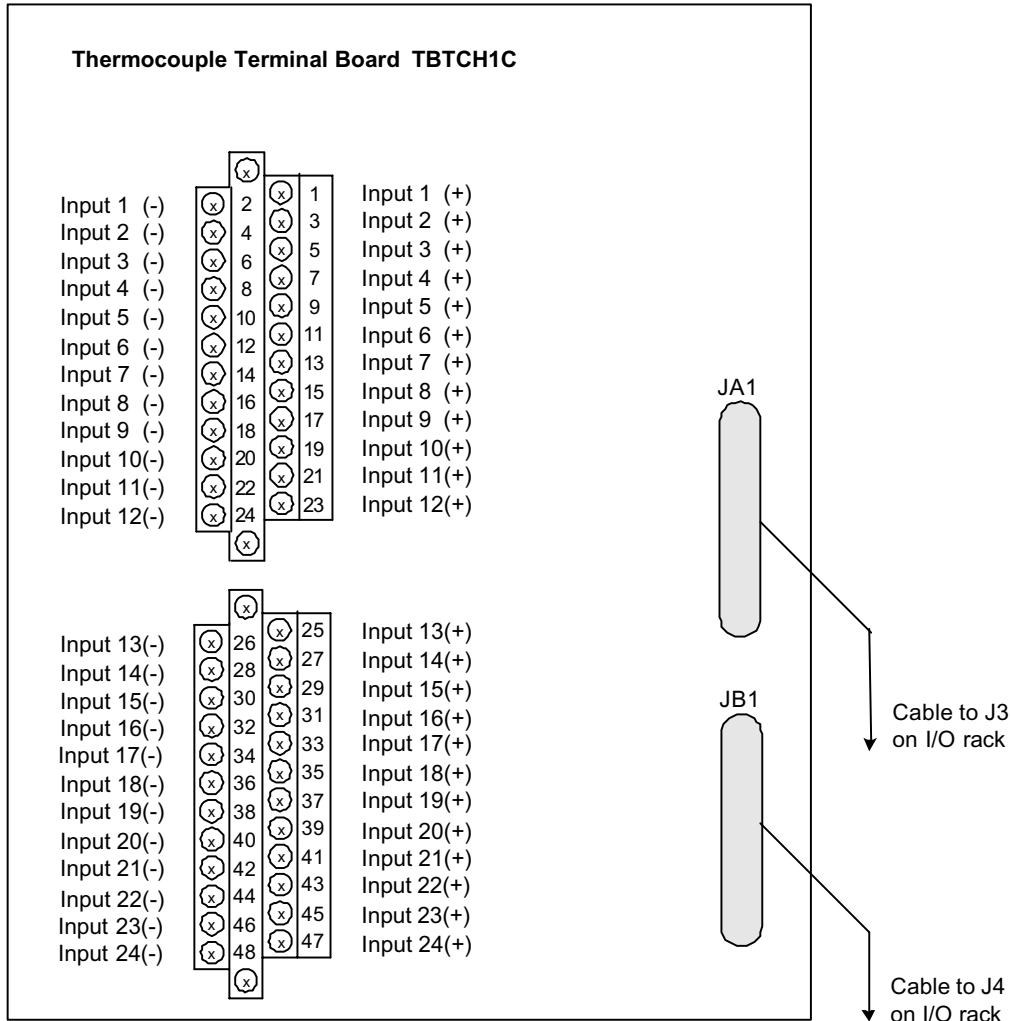

I/O terminal blocks with barrier terminals terminal blocks can be unplugged from terminal board for maintenance

Up to two #12 AWG wires per point with 300 V insulation

TMR version of this board has connectors JRA, JSA, and JTA for inputs 1-12, and connectors JRB, JSB, and JTB for inputs 13-24.

TBCH1C (Simplex) Wiring and Cabling

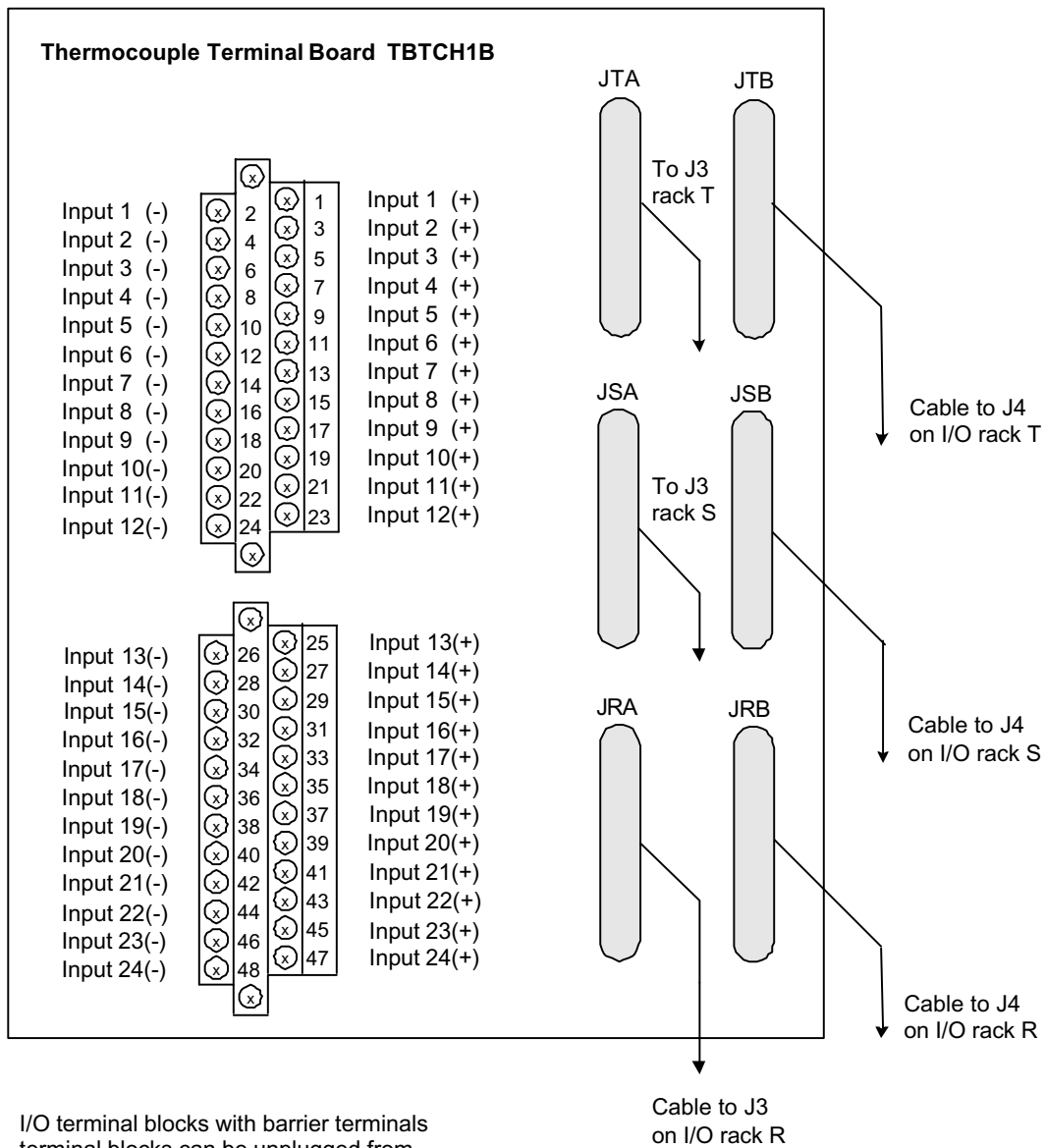

I/O terminal blocks with barrier terminals terminal blocks can be unplugged from terminal board for maintenance

Up to two #12 AWG wires per point with 300 volt insulation

TBCH1B (TMR) Wiring and Cabling

Operation

The 24 thermocouple inputs on the TBTC can be grounded or ungrounded. They can be located up to 300 meters (984 feet) from the turbine control cabinet with a maximum two-way cable resistance of 450 ohms. High frequency noise suppression and two cold junction reference devices are mounted on the board.

Linearization for individual thermocouple types is performed in software by VTCC. A thermocouple which is determined to be out of the hardware limits is removed from the scanned inputs in order to prevent adverse affects on other input channels. If both cold junction devices are within the configurable limits, then the average of the two is used for cold junction compensation. If only one cold junction device is within the configurable limits, then that cold junction is used for compensation. If neither cold junction device is within the configurable limits, then a default value is used.

Note VTCC boards manufactured after software version VTCC-100100C and higher have additional thermocouple and cold junction features. The new design boards permit the use of S-type thermocouples, in addition to all previous types. They also provide for a remote cold junction compensation feature for thermocouple inputs. This allows the user to select whether cold junction compensation is done based on a temperature reading at a remote location or at the terminal board as explained above. The calculations are the same as previous VTCC boards, only the source of the cold junction reading changes.

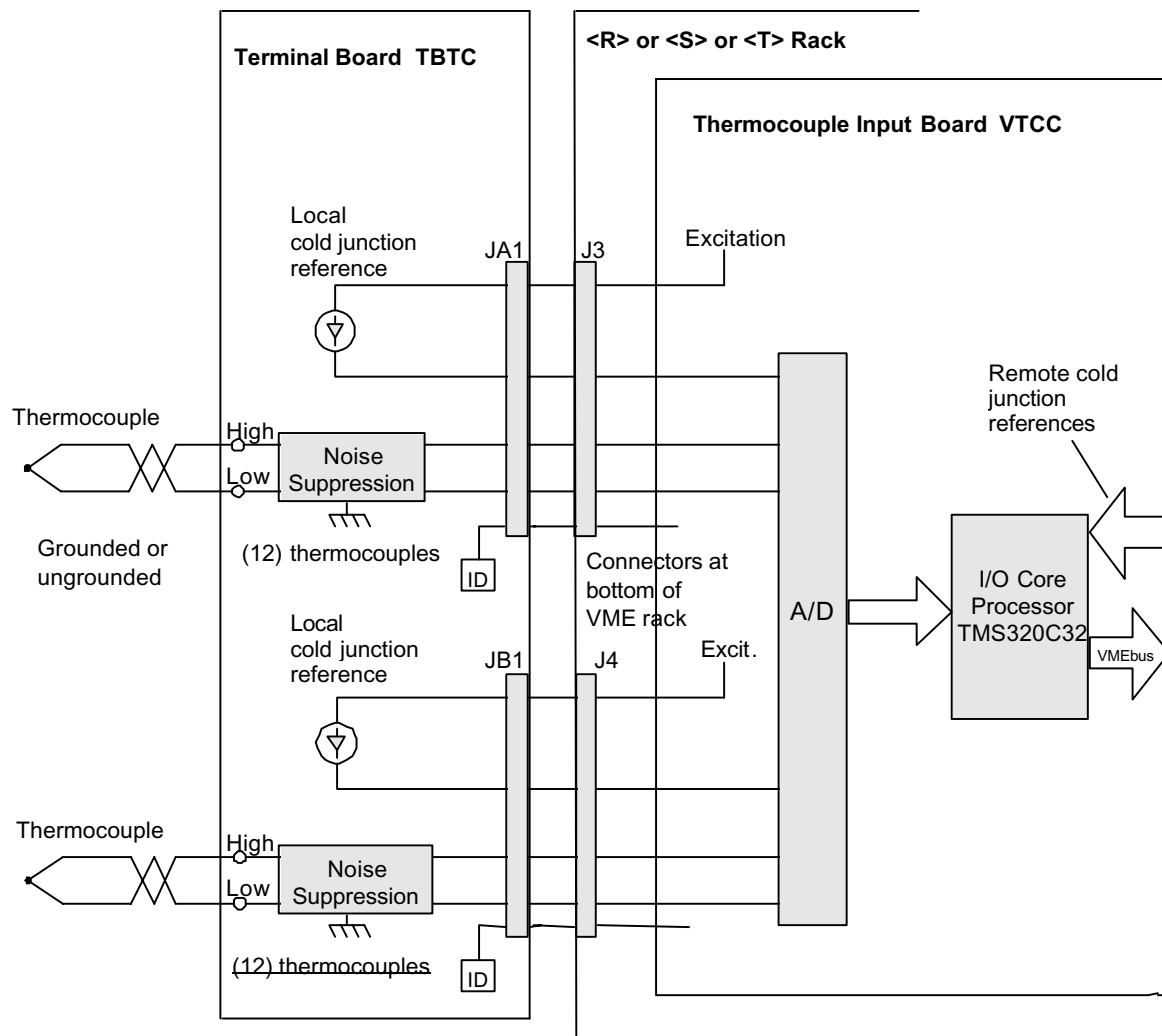

Simplex Thermocouple Inputs

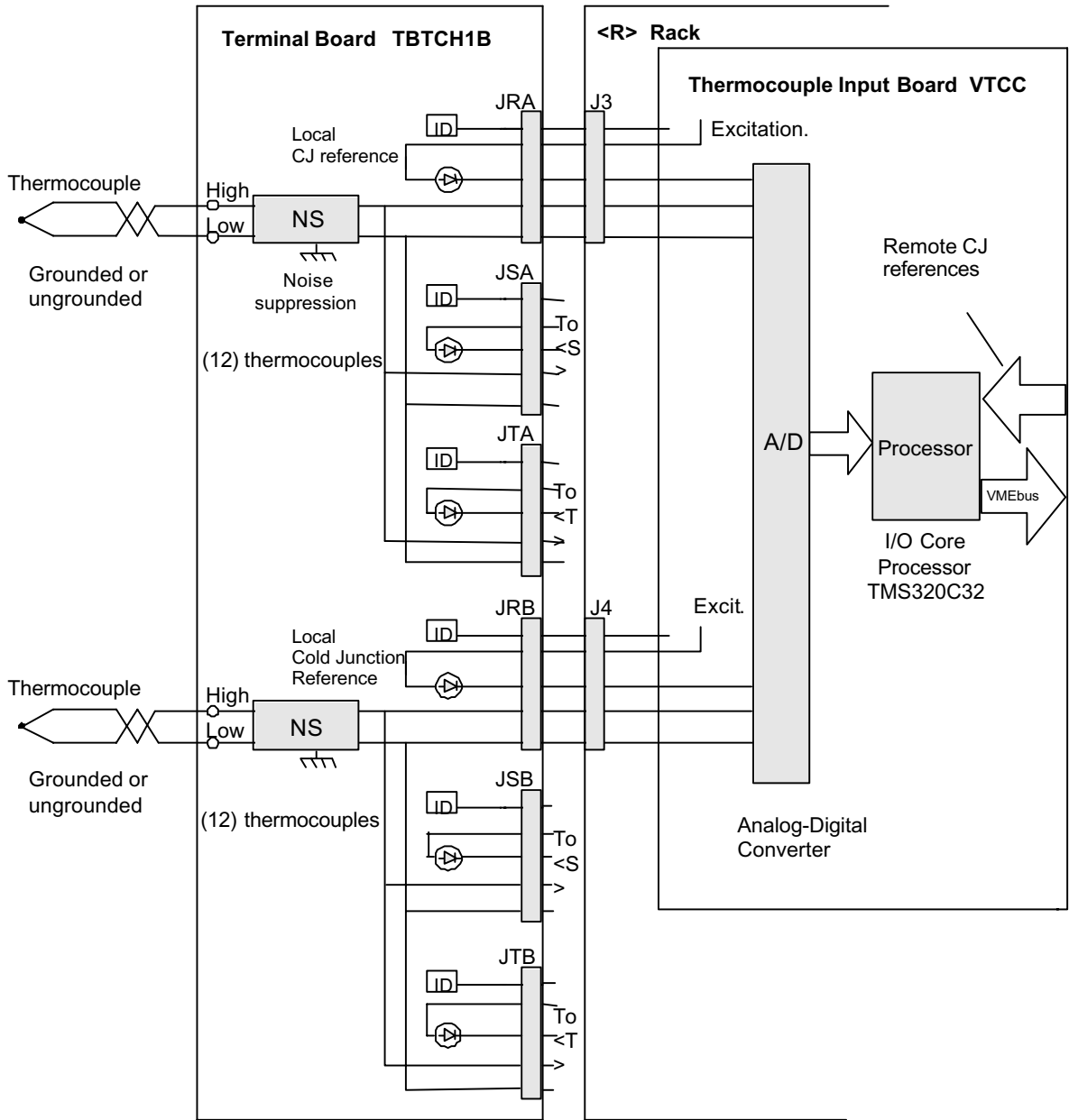

TMR Thermocouple Inputs

Thermocouple inputs are supported over a full-scale input range of -8.0 mV to $+45.0$ mV. The following table shows typical input voltages for different thermocouple types versus minimum and maximum temperature range. It is assumed the cold junction temperature ranges from $+32$ to $+158$ °F.

Thermocouple Types and Range

Thermocouple Type	E	J	K	S	T
Low range, °F / °C	-60 / -51	-60 / -51	-60 / -51	0 / -17.78	-60 / -51
mV at low range with reference at 158 °F (70 °C)	-7.174	-6.132	-4.779	-0.524	-4.764
High range, °F / °C	1100 / 593	1400 / 798	2000 / 1093	3200 / 1760	750 / 399
mV at high range with reference at 32 °F (0 °C)	44.547	42.922	44.856	18.612	20.801

The thermocouple inputs and cold junction inputs are automatically calibrated using the filtered calibration reference and zero voltages.

There are two cold junction references used per VTCC, one for connector J3 and J4. Each reference can be selected as either remote (from VME bus) or local (from associated terminal board, T type or D type). All references are then treated as sensor inputs (for example, averaged, limits configured). The two references can be mixed, one local and one remote. Cold junction signals go into signal space and are available for monitoring. Normally the average of the two is used. Acceptable limits are configured, and if a cold junction goes outside the limit, a logic signal is set. A 1 °F error in the cold junction compensation causes a 1 °F error in the TC reading.

Hard coded limits are set at 32 to 158 °F, and if a cold junction goes outside these, it is regarded as bad. Most cold junction failures are open or short circuit. If one cold junction fails, the good one is used. If both cold junctions go bad, the backup value is used, which can be derived from cold junction readings on other terminal boards, or can be the configured default value.

Specifications

Typical VTCC Specification

Item	Specification
Number of channels	24 channels per terminal board and I/O board
Thermocouple types	E, J, K, S, T thermocouples, and mV inputs
Span	-8 mV to +45 mV
A/D converter	Sampling type 16-bit A/D converter with better than 14-bit resolution
CJ compensation	Reference junction temperature measured at two locations on each TC terminal board (optional for remove CJs). TMR board has six cold junction references.
Cold junction temperature accuracy	Cold junction accuracy 2 °F
Conformity error	Maximum software error 0.25 °F
Measurement accuracy	53 microvolts (excluding cold junction reading) Example: 3 °F, type K, at 1000 °F, including cold junction contribution (RSS)
Common mode rejection	Ac common mode rejection 110 dB @ 50/60 Hz, for balanced impedance input
Common mode voltage	±5 V
Normal mode rejection	Rejection of 250 mV rms is 80 dB @ 50/60 Hz
Scan time	All inputs are sampled at 120 times per second for 60 Hz operation; for 50 Hz operation it is 100 times per second
Fault detection	High/low (hardware) limit check High/low system (software) limit check Monitor readings from all TCs, CJs, calibration voltages, and calibration zero readings

Diagnostics

Three LEDs at the top of the front panel provide status information. The normal RUN condition is a flashing green, and FAIL is a solid red. The third LED shows a steady orange if a diagnostic alarm condition exists in the board.

Each thermocouple type has Hardware Limit Checking based on preset (non-configurable) high and low levels set near the ends of the operating range. If this limit is exceeded a logic signal is set and the input is no longer scanned. If any one of the 24 inputs hardware limits is set it creates a composite diagnostic alarm, L3DIAG_VTCC, referring to the entire board. Details of the individual diagnostics are available from the toolbox. The diagnostic signals can be individually latched, and then reset with the RESET_DIA signal.

In TMR, systems limit logic signals are voted and the resulting composite diagnostic is present in each controller.

Each thermocouple input has system limit checking based on configurable high and low levels. These limits can be used to generate alarms, and can be configured for enable/disable, and as latching/nonlatching. RESET_SYS resets the out of limit signals.

Each terminal board cable has its own ID device, which is interrogated by the I/O board. The board ID is coded into a read-only chip containing the terminal board serial number, board type, revision number, and the JA1/JB1 connector location.

The TMR version of this board has six ID devices, one for each cable connector. Details of the VTCC diagnostics are in GEH-6421D, Vol. I *Mark VI System Guide*, Chapter 8, *Troubleshooting and Diagnostics*.

The thermocouple board is configured using the toolbox. The following table summarizes configuration choices and defaults. For details refer to GEH-6403, *Control System Toolbox for Configuring the Mark VI Controller*.

Configuration

Thermocouple Board Configuration (Part 1 of 2)

Parameter	Description	Choices
Configuration		
SysFreq	System frequency (used for noise rejection)	50 or 60 Hz
SystemLimits	Enables or disables all system limit checking	Enable, disable
Auto Reset	Automatic Restoring of Thermocouples removed from scan	Enable, disable
J3J4:I200BTCH1A	Terminal board	Connected, Not Connected
ThermCpl1	First of 24 thermocouples - board point signal	Point edit (input FLOAT)
ThermoCpl Type	Thermocouples supported by VTCC; unused inputs are removed from scanning, mV inputs are primarily for maintenance. When configured for mV input, the signal span is –8 mV to +45 mV. The input is not compensated for CJ and is a straight reading of the terminal board mV input. In order to detect open wires, each input is biased using plus and minus 0.25 V through 10 megohm resistors. This should be taken into account if high impedance mV signals are to be read.	Unused, mV, S, T, K, J, E
LowPassFiltr	Enable 2 Hz low pass filter	Enable, disable
SysLim1 Enabl	Enables or disables a temperature limit which can be used to create an alarm.	Enable, disable
SysLim1 Latch	Determines whether the limit condition will latch or unlatch; reset used to unlatch.	Latch, unlatch
SysLim1 Type	Limit occurs when the temperature is greater than or equal (\geq), or less than or equal to (\leq) a preset value.	Greater than or equal, less than or equal
SysLimit 1	Enter the desired value.	Engineering units
SysLim2 Enabled	Enables or disables a temperature limit which can be used to create an alarm.	Enable, disable
SysLim2 Latch	Determines whether the limit condition will latch or unlatch; reset used to unlatch.	Latch, unlatch
SysLim2 Type	Limit occurs when the temperature is greater than or equal (\geq), or less than or equal to (\leq) a preset value.	Greater than or equal, less than or equal
SysLimit 2	Enter the desired value.	Engineering units
TMR Diff Limt	Limit condition occurs if 3 temperatures in R, S, T differ by more than a preset value (deg F); this creates a voting alarm condition.	–60 to 2,000
ColdJunc1	First CJ reference - Board point signal (similar configuration as for thermocouples but no low pass filter or CJ type choices of local or remote).	As above (input FLOAT)
ColdJunc2	Second CJ reference – Board point signal (similar configuration as for thermocouples but no low pass filter or CJ type choices of local or remote).	As above (input FLOAT)

Thermocouple Board Configuration (Part 2 of 2)

Board Points (Signals)	Description - Point Edit (Enter Signal Connection Name)	Direction Type
L3DIAG_VTCC1	Board diagnostic	Input BIT
L3DIAG_VTCC2	Board diagnostic	Input BIT
L3DIAG_VTCC3	Board diagnostic	Input BIT
SysLim1TC1	System limit 1 for thermocouple	Input BIT
:	:	Input BIT
SysLim1TC24	System limit 1 for thermocouple	Input BIT
SysLim1CJ1	System limit 1 for CJ	Input BIT
SysLim1JC2	System limit 1 for CJ	Input BIT
SysLim2TC1	System limit 2 for thermocouple	Input BIT
:	:	Input BIT
SysLim2TC24	System limit 2 for thermocouple	Input BIT
SysLim2CJ1	System limit 2 for CJ	Input BIT
SysLim2CJ2	System limit 2 for CJ	Input BIT
CJ Backup	CJ backup	Output FLOAT
CJ Remote 1	CJ remote 1	Output FLOAT
CJ Remote 2	CJ remote 2	Output FLOAT
ThermCpl1	Thermocouple reading	Input FLOAT
:	:	Input FLOAT
ThermCpl24	Thermocouple reading	Input FLOAT
ColdJunc1	CJ for TC's 1–12	Input FLOAT
ColdJunc2	CJ for TC's 13–24	Input FLOAT

DTTC Simplex Thermocouple Terminal Board

The DTCC board is a compact terminal board designed for DIN-rail mounting. The board has 12 thermocouple inputs and connects to the VTCC thermocouple processor board with a single 37-pin cable. This cable is identical to the one used on the larger TBCC terminal board. The on-board signal conditioning and cold junction reference are identical to those on the TBTC board.

An on-board ID chip identifies the board to the VTCC for system diagnostic purposes.

Two DTTC boards can be connected to the VTCC for a total of 24 inputs. Only the simplex version of the board is available. The terminal boards can be stacked vertically on the DIN-rail to conserve cabinet space. High density Euro-Block type terminal blocks are permanently mounted to the board with two screw connections for the ground connection (SCOM). Every third screw connection is for the shield.

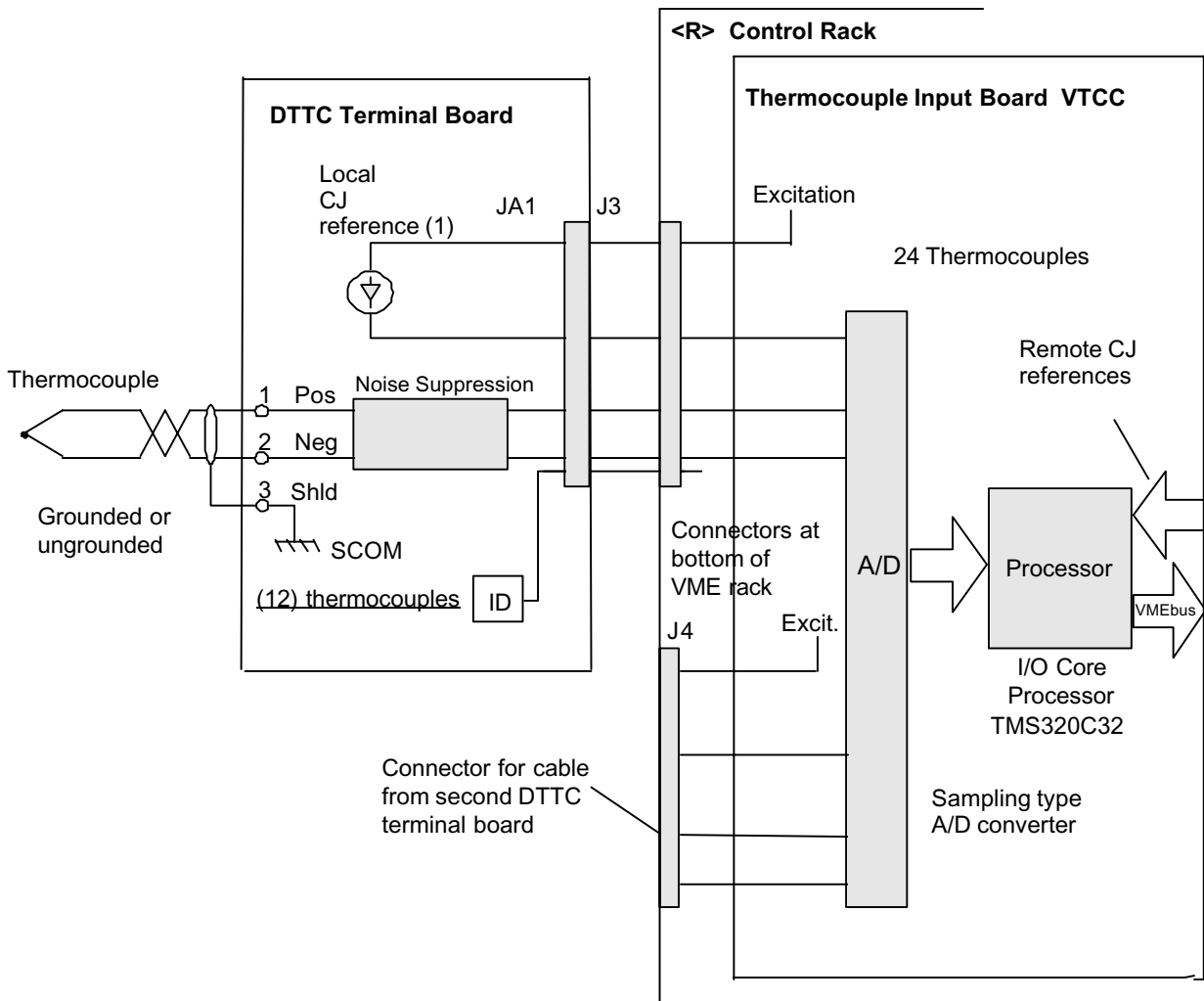

DTTC for Thermocouple Inputs

Installation

Shield screws are provided on this board, internally connected to SCOM.

The DTTC board slides into a plastic holder which mounts on the DIN-rail. Thermocouples are wired directly to the terminal block. The Euro-Block type terminal block has 42 terminals and is permanently mounted on the terminal board. Typically #18 AWG wires are used. There are two screws for the SCOM (ground) connection, which should be as short a distance as possible.

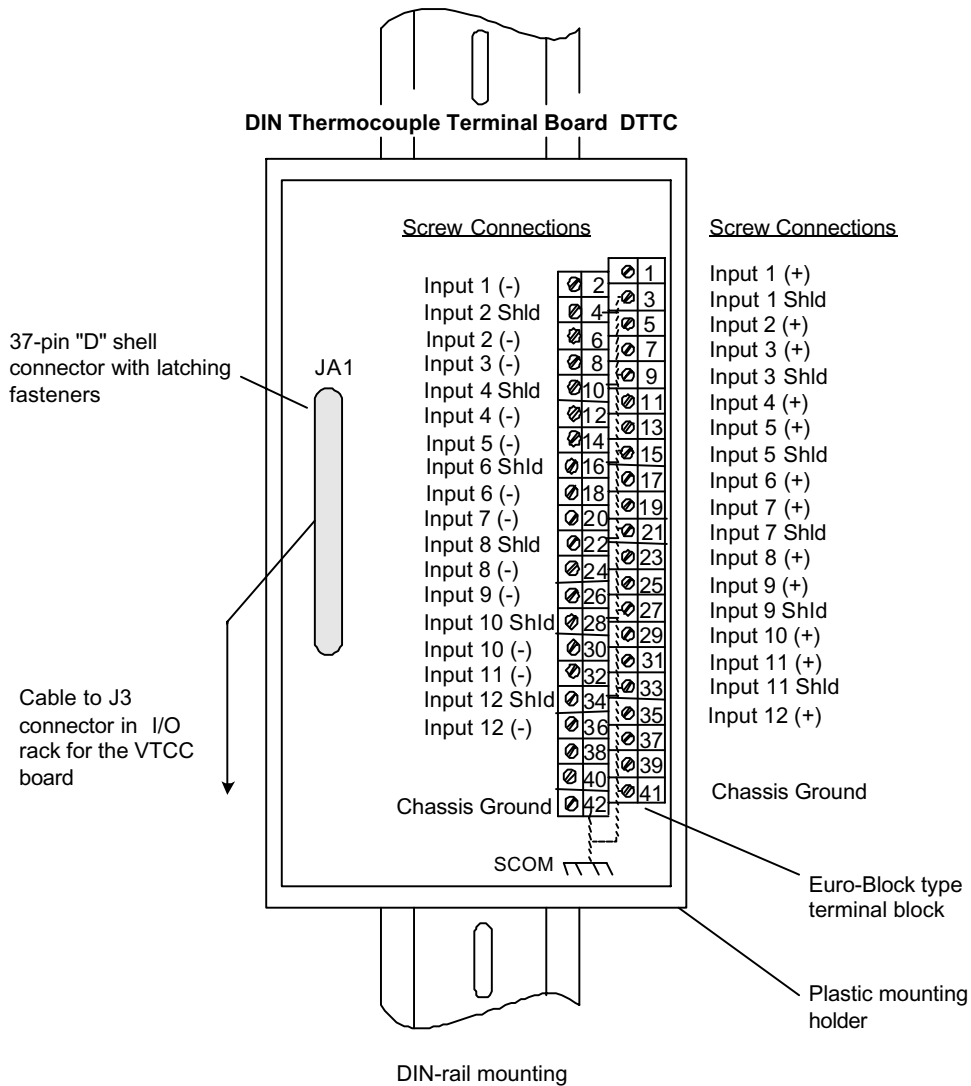

DTTC Wiring and Cabling

I/O Board Alarms

Diagnostic alarms for any I/O board can be displayed and reset from the toolbox. For troubleshooting and general diagnostic alarm information refer to GEH-6421 Volume I, Chapter 8.

I/O Board Diagnostic Alarms

Board	Fault	Fault Description	Possible Cause
VTCC	2	Flash Memory CRC Failure	Board firmware programming error (board will not go online)
	3	CRC failure override is Active	Board firmware programming error (board is allowed to go online)
	16	System Limit Checking is Disabled	System checking was disabled by configuration.
	17	Board ID Failure	Failed ID chip on the VME I/O board
	18	J3 ID Failure	Failed ID chip on connector J3, or cable problem
	19	J4 ID Failure.	Failed ID chip on connector J4, or cable problem
	20	J5 ID Failure	Failed ID chip on connector J5, or cable problem
	21	J6 ID Failure	Failed ID chip on connector J6, or cable problem
	22	J3A ID Failure	Failed ID chip on connector J3A, or cable problem
	23	J4A ID Failure	Failed ID chip on connector J4A, or cable problem
	24	Firmware/Hardware Incompatibility	Invalid terminal board connected to VME I/O board
	30	ConfigCompatCode mismatch; Firmware: #; Tre: # The configuration compatibility code that the firmware is expecting is different than what is in the tre file for this board	A tre file has been installed that is incompatible with the firmware on the I/O board. Either the tre file or firmware must change. Contact the factory.
	31	IOCompatCode mismatch; Firmware: #; Tre: # The I/O compatibility code that the firmware is expecting is different than what is in the tre file for this board	A tre file has been installed that is incompatible with the firmware on the I/O board. Either the tre file or firmware must change. Contact the factory.
	32-55	Thermocouple ## Raw Counts High. The ## thermocouple input to the analog to digital converter exceeded the converter limits and will be removed from scan	A condition such as stray voltage or noise caused the input to exceed +63 millivolts.
56-79	Thermocouple ## Raw Counts Low. The ## thermocouple input to the analog to digital converter exceeded the converter limits and will be removed from scan	The board has detected a thermocouple open and has applied a bias to the circuit driving it to a large negative number, or the TC is not connected, or a condition such as stray voltage or noise caused the input to exceed -63 millivolts.	

80,81	Cold Junction # Raw Counts High. Cold junction device number # input to the A/D converter has exceeded the limits of the converter. Normally two cold junction inputs are averaged; if one is detected as bad then the other is used. If both cold junctions fail, a predetermined value is used	The cold junction device on the terminal board has failed.
82,83	Cold Junction # Raw Counts Low. Cold junction device number # input to the A/D converter has exceeded the limits of the converter. Normally two cold junction inputs are averaged; if one is detected as bad then the other is used. If both cold junctions fail, a predetermined value is used	The cold junction device on the terminal board has failed.
84,85	Calibration Reference # Raw Counts High. Calibration Reference # input to the A/D converter exceeded the converter limits. If Cal. Ref. 1, all even numbered TC inputs will be wrong; if Cal. Ref. 2, all odd numbered TC inputs will be wrong	The precision reference voltage on the board has failed.
86,87	Calibration Reference # Raw Counts Low. Calibration Reference # input to the A/D converter exceeded the converter limits. If Cal. Ref. 1, all even numbered TC inputs will be wrong; if Cal. Ref. 2, all odd numbered TC inputs will be wrong	The precision reference voltage on the board has failed.
88,89	Null Reference # Raw Counts High	The null reference voltage signal on the board has failed.
90,91	Null Reference # Raw Counts Low. The null (zero) reference number # input to the A/D converter has exceeded the converter limits. If null ref. 1, all even numbered TC inputs will be wrong; if null ref. 2, all odd numbered TC inputs will be wrong	The null reference voltage signal on the board has failed.
92-115	Thermocouple ## Linearization Table High. The thermocouple input has exceeded the range of the linearization (lookup) table for this type. The temperature will be set to the table's maximum value	The thermocouple has been configured as the wrong type, or a stray voltage has biased the TC outside of its normal range, or the cold junction compensation is wrong.
116-139	Thermocouple ## Linearization Table Low. The thermocouple input has exceeded the range of the linearization (lookup) table for this type. The temperature will be set to the table's minimum value	The thermocouple has been configured as the wrong type, or a stray voltage has biased the TC outside of its normal range, or the cold junction compensation is wrong.
160-255	Logic Signal # Voting mismatch	A problem with the input. This could be the device, the wire to the terminal board, the terminal board, or the cable.
256-281	Input Signal # Voting mismatch, Local #, Voted #. The specified input signal varies from the voted value of the signal by more than the TMR Diff Limit	A problem with the input. This could be the device, the wire to the terminal board, the terminal board, or the cable.



GE Industrial Systems

+1 540 387 7000
[www. Geindustrial.com](http://www.Geindustrial.com)

General Electric Company
1501 Roanoke Blvd.
Salem, VA 24153-6492 USA



GEI-100554

GE Industrial Systems

VRTD Processor Board

Board Specification

These instructions do not purport to cover all details or variations in equipment, nor to provide for every possible contingency to be met during installation, operation, and maintenance. The information is supplied for informational purposes only, and GE makes no warranty as to the accuracy of the information included herein. Changes, modifications and/or improvements to equipment and specifications are made periodically and these changes may or may not be reflected herein. It is understood that GE may make changes, modifications, or improvements to the equipment referenced herein or to the document itself at any time. This document is intended for trained personnel familiar with the GE products referenced herein.

GE may have patents or pending patent applications covering subject matter in this document. The furnishing of this document does not provide any license whatsoever to any of these patents. All license inquiries should be directed to the address below. If further information is desired, or if particular problems arise that are not covered sufficiently for the purchaser's purpose, the matter should be referred to:

GE Industrial Systems

Post Sales Service

1501 Roanoke Blvd.

Salem, VA 24153-6492 USA

Phone: + 1 888 GE4 SERV (888 434 7378, United States)

+ 1 540 378 3280 (International)

Fax: + 1 540 387 8606 (All)

("+" indicates the international access code required when calling from outside the USA)

This document contains proprietary information of General Electric Company, USA and is furnished to its customer solely to assist that customer in the installation, testing, operation, and/or maintenance of the equipment described. This document shall not be reproduced in whole or in part nor shall its contents be disclosed to any third party without the written approval of GE Industrial Systems.

GE PROVIDES THE FOLLOWING DOCUMENT AND THE INFORMATION INCLUDED THEREIN AS IS AND WITHOUT WARRANTY OF ANY KIND, EXPRESS OR IMPLIED, INCLUDING BUT NOT LIMITED TO ANY IMPLIED STATUTORY WARRANTY OF MERCHANTABILITY OR FITNESS FOR PARTICULAR PURPOSE.

ISSUE DATE: 2002-06-30

© 2002 by General Electric Company, USA.

All rights reserved.

Section	Page
Functional Description.....	2
Installation	4
Operation.....	6
Specifications.....	8
Diagnostics	9
Configuration	10
DRTD Simplex Thermocouple Terminal Board	12
Installation	13
I/O Board Alarms	14

Functional Description

The Resistance Temperature Device (RTD) processor board (VRTD) accepts 16, three-wire RTD inputs. These inputs are wired to two barrier type blocks on the RTD terminal board (TRTD). Inputs to TRTD have noise suppression circuitry to protect against surge and high frequency noise. Cables with molded fittings connect the terminal board to the VME rack where the VRTD processor board is located.

There are two versions of TRTD, simplex and a TMR version that fans out the signals to three VRTD boards. VRTD converts the inputs to digital temperature values and transfers them over the VME backplane to the VCMI, and then to the controller.

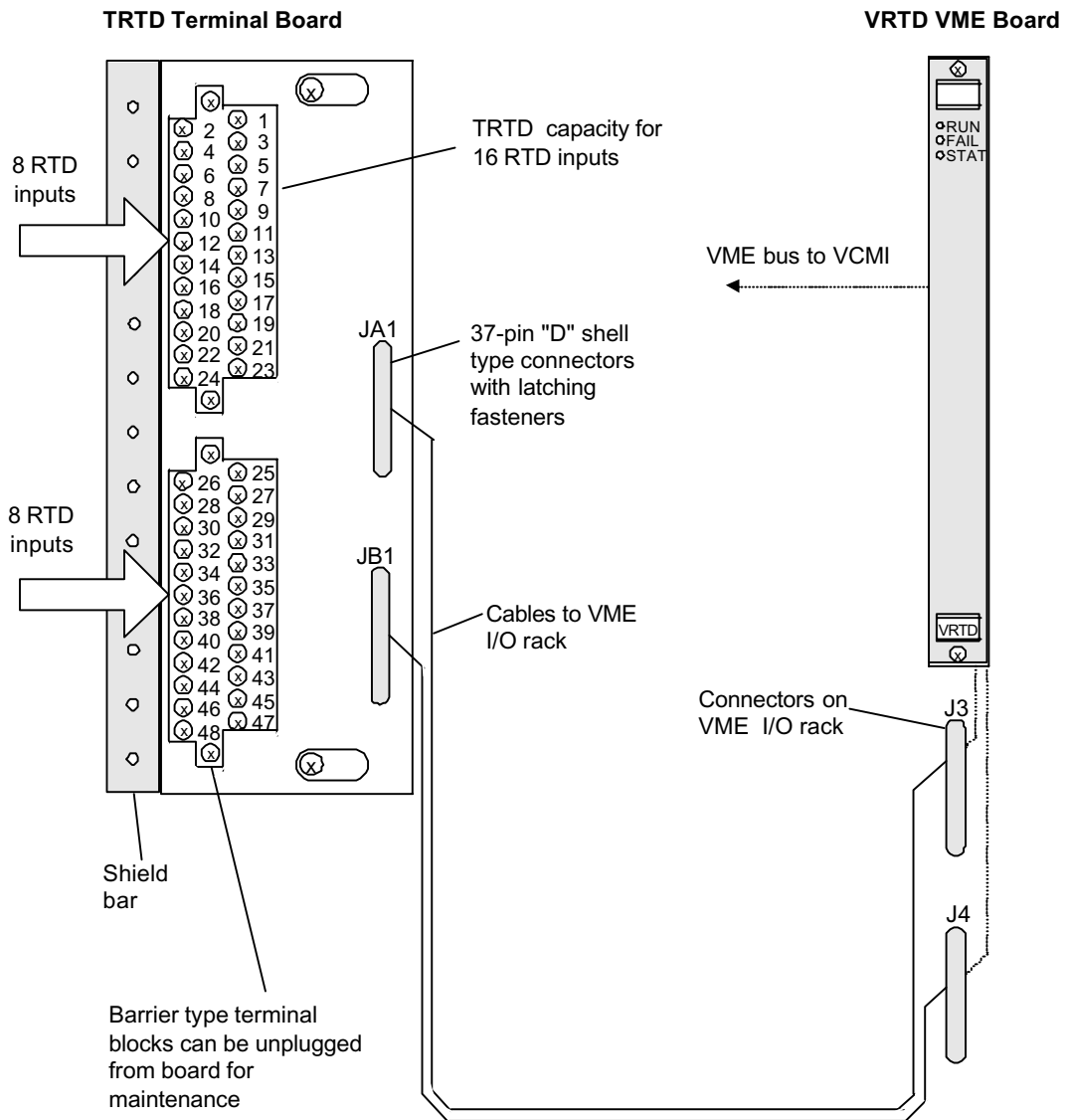

RTD Input Terminal Board, I/O Board, and Cabling

Installation

The sixteen RTDs are wired directly to two I/O terminal blocks mounted on the terminal board. Each block is held down with two screws and has 24 terminals accepting up to #12 AWG wires. A shield termination strip attached to chassis ground is located immediately to the left of each terminal block.

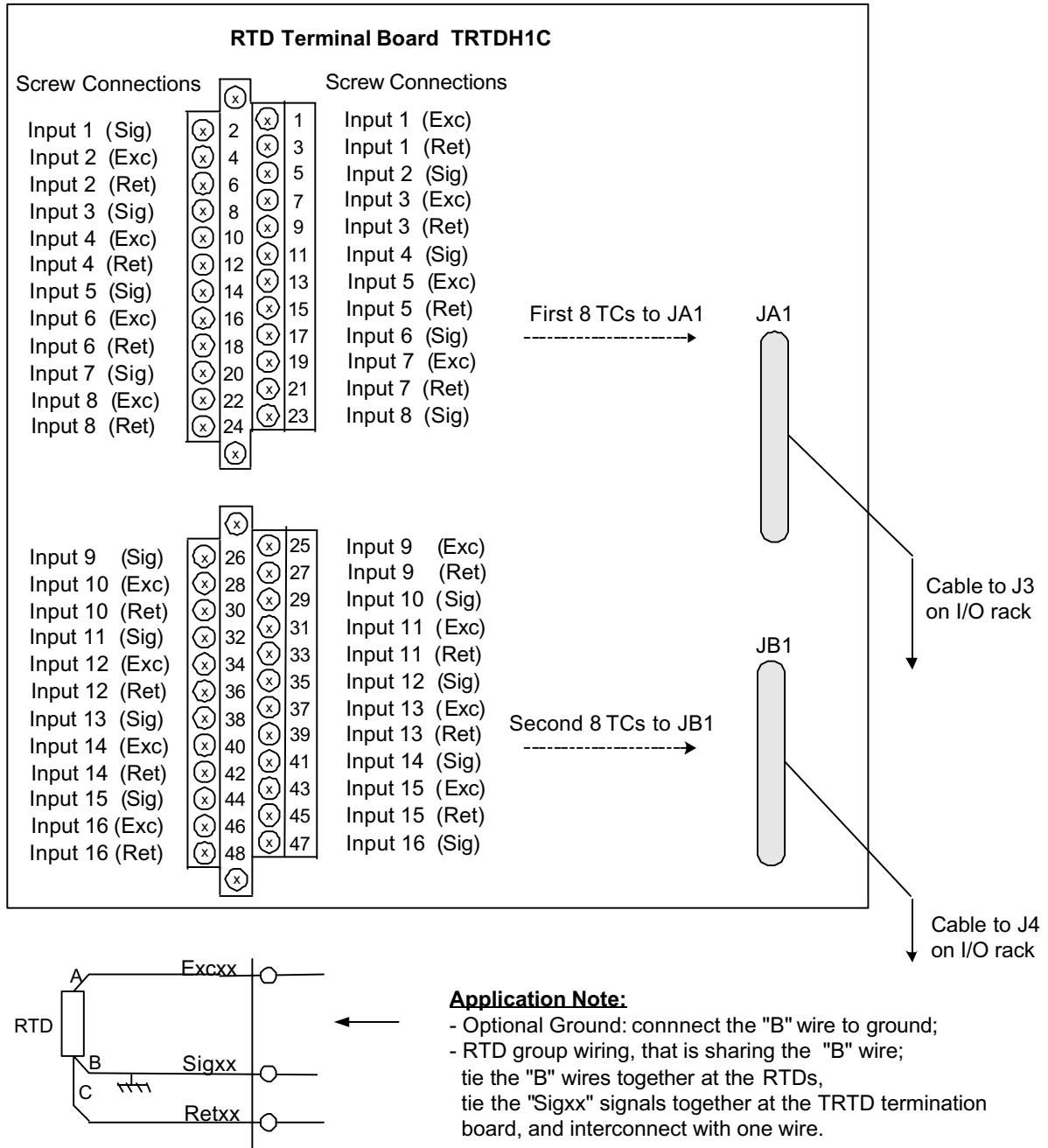

TRTDH1C (Simplex) Board Wiring

TRTDH1B provides redundant RTD inputs by fanning the inputs out to VRTD boards in the R, S, and T. The inputs meet the same environmental, codes, resolution, suppression, and function requirements as with the TRTD terminal board, however, the fast scan is not available.

All RTD signals have high frequency decoupling to ground at signal entry. RTD multiplexing on the VRTD boards is coordinated by redundant pacemakers so that the loss of a single cable or loss of a single VRTD does not cause the loss of any RTD signals in the control database. VRTD boards in R, S, and T read RTDs simultaneously, but skewed by two RTDs, so that when R is reading RTD3, S is reading RTD5, and T is reading RTD7, and so on. This ensures that the same RTD is not excited by two VRTDs simultaneously, and hence produce bad readings.

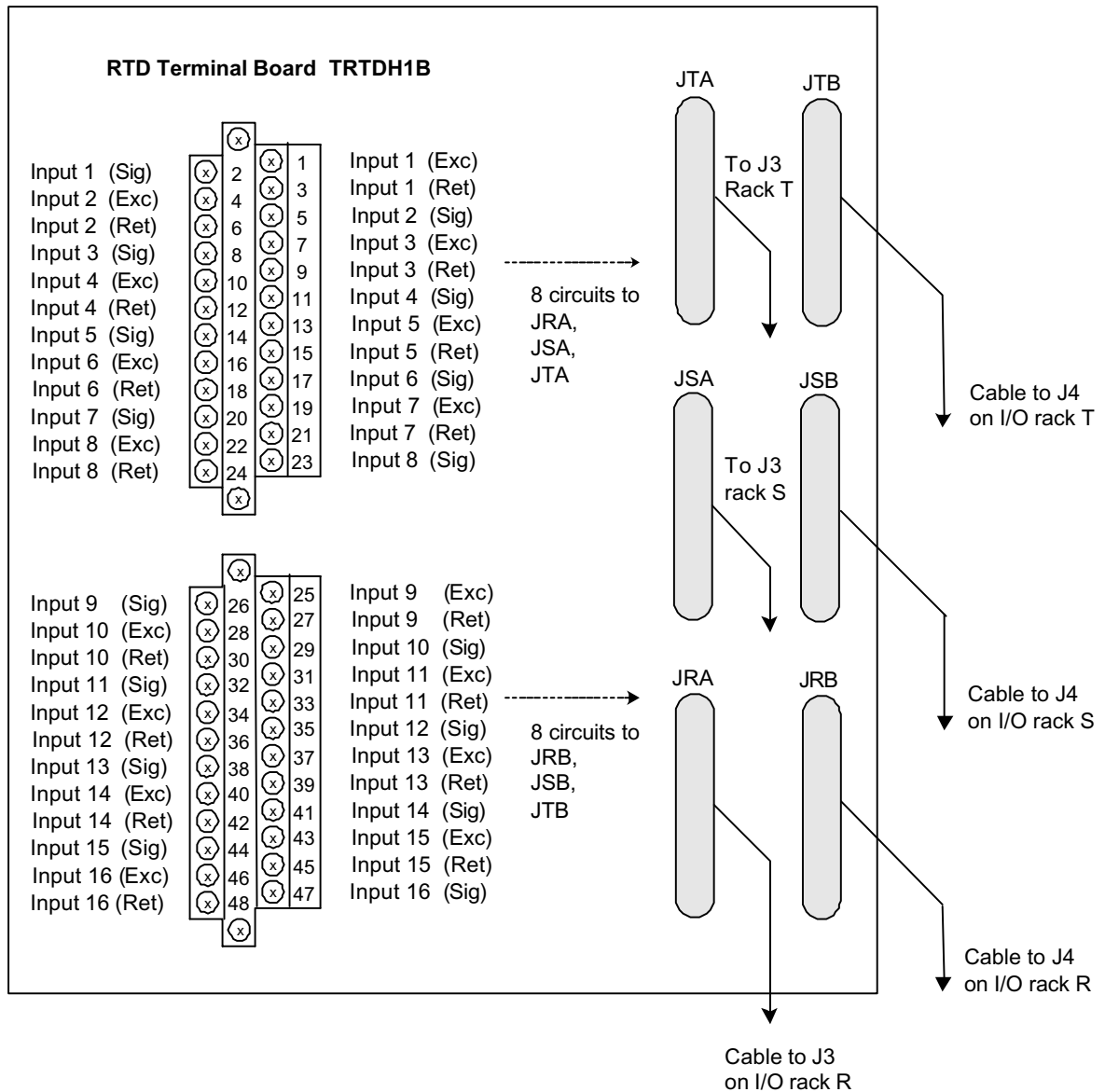

TRTDH1B (TMR) Board Wiring

Operation

The terminal board supplies a 10 mA dc multiplexed (not continuous) excitation current to each RTD, which can be grounded or ungrounded. The 16 RTDs can be located up to 300 meters (984 feet) from the turbine control cabinet with a maximum two-way cable resistance of 15 ohms.

The VCO type A/D converter in the VRTD board uses voltage to frequency converters and sampling counters. The converter samples each signal and the excitation current four times per second for normal mode scanning, and 25 times per second for fast mode scanning, using a time sample interval related to the power system frequency. Linearization for the selection of 15 RTD types is performed in software by the digital signal processor.

RTD open and short circuits are detected by out of range values. An RTD that is determined to be out of hardware limits is removed from the scanned inputs in order to prevent adverse affects on other input channels. Repaired channels are reinstated automatically in 20 seconds, or can be manually reinstated.

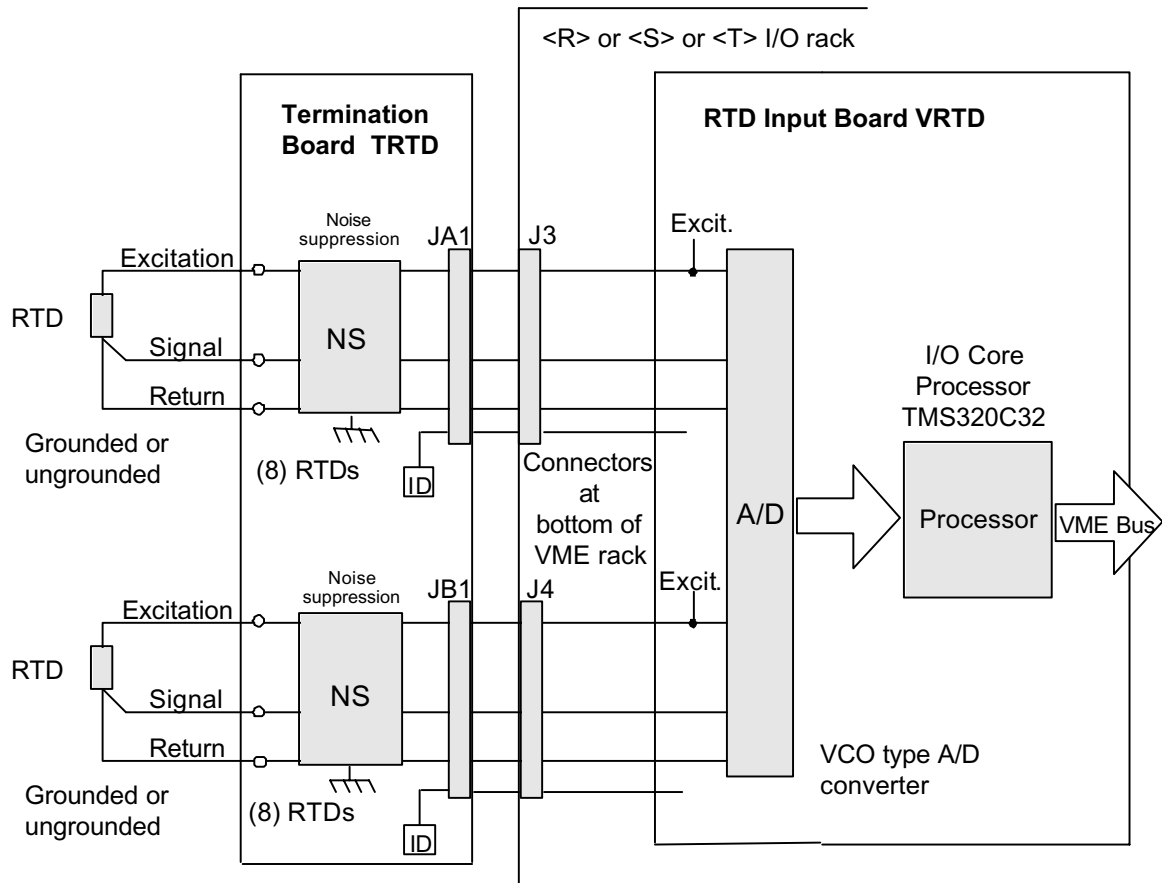

TRTD (Simplex) Inputs and Signal Processing

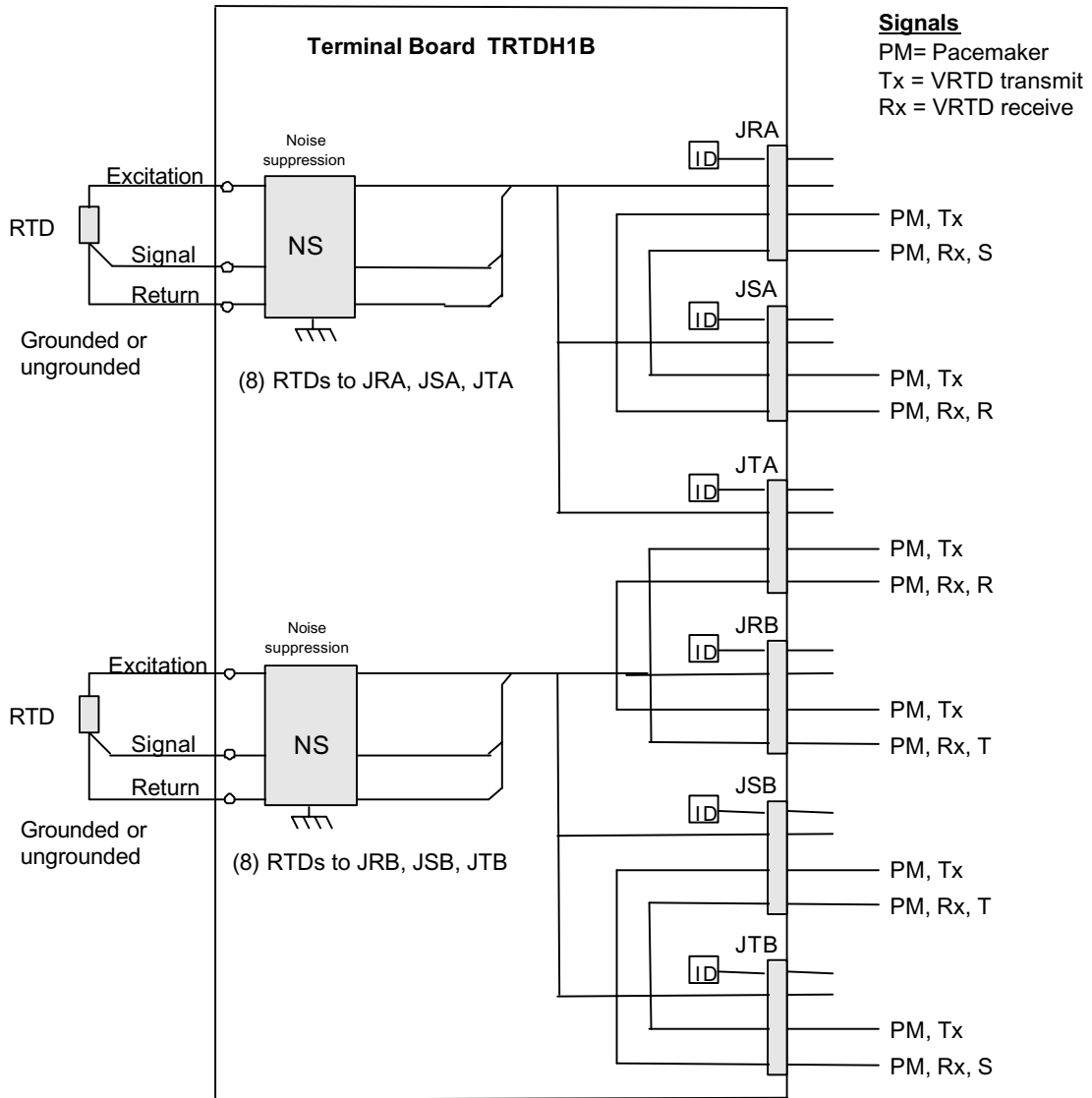

TRTD (TMR) Inputs and Signal Processing

Specifications

RTD Specifications

Item	Specification
Number of channels	16 channels per terminal board 16 channels per VRTD board
RTD types	10, 100, and 200 ohm platinum 10 ohm copper 120 ohm nickel
Span	0.3532 to 4.054 volts
A/D converter resolution	14-bit resolution
Scan Time	Normal scan 250 ms (4 Hz) Fast scan 40 ms (25 Hz)
Power consumption	Less than 12 watts
Measurement accuracy	See Tables
Common mode rejection	Ac common mode rejection 60 dB @ 50/60 Hz Dc common mode rejection 80 dB
Common mode voltage range	± 5 V
Normal mode rejection	Rejection of up to 250 mV rms is 60 dB @ 50/60 Hz system frequency for normal scan
Maximum lead resistance	15 ohms maximum two way cable resistance
Fault detection	High/low (hardware) limit check High/low (software) system limit check

VRTD Accuracy

RTD Type	Group Gain	Accuracy at 400 °F
120 ohm nickel	Normal_ 1.0	2 °F
200 ohm platinum	Normal_ 1.0	2 °F
100 ohm platinum	Normal_ 1.0	4 °F
100 ohm platinum (-60 °F to 400 °F)	Gain_ 2.0	2 °F
10 ohm copper	10 ohm Cu_10	10 °F

VRTD Types and Ranges

RTD Type	Name/Standard	Range degree C	Range degree F
10 ohm copper	MINCO_CA GE 10 Ohm Copper	-51 to +260	-60 to +500
100 ohm platinum	SAMA 100	-51 to +593	-60 to +1100
100 ohm platinum	DIN 43760 IEC-751 MINCO_PD MINCO_PE PT100_DIN	-51 to +700	-60 to +1292
100 ohm platinum	MINCO_PA IPTS-68 PT100_PURE	-51 to +700	-60 to +1292
100 ohm platinum	MINCO_PB Rosemount 104 PT100_USIND	-51 to +700	-60 to +1292
120 ohm nickel	MINCO_NA N 120	-51 to +249	-60 to +480
200 ohm platinum	PT 200	-51 to +204	-60 to +400

Diagnostics

Three LEDs at the top of the VRTD front panel provide status information. The normal RUN condition is a flashing green and FAIL is a solid red. The third LED is normally off but shows a steady orange if a diagnostic alarm condition exists in the board.

Two types of diagnostic checking are applied to all inputs, hardware limit checking and system limit checking.

Each RTD type has hardware limit checking based on preset (non-configurable) high and low levels set near the ends of the operating range. If this limit is exceeded a logic signal is set and the input is no longer scanned. If any one of the 16 input's hardware limits is set it creates a composite diagnostic alarm, L3DIAG_VRTD, referring to the entire board. Details of the individual diagnostics are available from the toolbox. The diagnostic signals can be individually latched, and then reset with the RESET_DIA signal.

Each RTD input has system limit checking based on configurable high and low levels. These limits can be used to generate alarms, and can be configured for enable/disable, and as latching/nonlatching. RESET_SYS resets the out of limit signals. In TMR systems limit logic signals are voted and the resulting composite diagnostic is present in each controller.

Each connector has its own ID device, which is interrogated by the I/O board. The board ID is coded into a read-only chip containing the terminal board serial number, board type, revision number, and the JA1/JB1 connector location. The TMR board version has six ID chips, one for each connector.

Descriptions of the VRTD diagnostics are in GEH-6421D, Vol. I *Mark VI System Guide*, Chapter 8, *Troubleshooting and Diagnostics*.

Configuration

Like all I/O boards, the RTD board is configured using the toolbox. This software usually runs on a data highway connected CIMPLICITY station or workstation. For details refer to GEH-6403, *Control System Toolbox for Configuring the Mark VI Turbine Controller*.

Typical VRTD Configuration

Module Parameter	Description	Choices
Configuration		
System limits	Enable or disable all system limit checking	Enable, disable
Auto reset	Enable or disable restoring of RTDs removed from scan	Enable, disable
Group A rate	Sampling rate and system frequency filter for first group of 8 inputs	4 Hz, 50 Hz filter 4 Hz, 60 Hz filter 25 Hz
Group A gain	Gain 2.0 is for higher accuracy if ohms <190, first group of 8 inputs	Normal_1.0 Gain_2.0 10 ohm Cu_10.0
Group B rate	Sampling rate and system frequency filter for second group of 8 inputs	4 Hz, 50 Hz filter 4 Hz, 60 Hz filter 25 Hz
Group B gain	Gain 2.0 is for higher accuracy if ohms <190, second group of 8 inputs	Normal_1.0 Gain_2.0 10 ohm Cu_10.0
J3J4:IS200TRTDH1C	Terminal board	Connected, not connected
RTD1	First of 16 RTDs - Board point signal	Point edit (input FLOAT)
RTD type	RTDs linearizations supported by VRTD; select RTD or Ohms Input (unused inputs are removed from scanning)	Unused CU10 MINCO_CA PT100_DIN MINCO_PD PT100_PURE MINCO_PA PT100_USIND MINCO_PB N120 MINCO_NA MINCO_PIA PT100_SAMA PT200 MINCO_PK Ohms
SysLim1 Enable	Enables or disables a temperature limit for each RTD, can be used to create an alarm	Enable, disable
SysLim1 Latch	Determines whether the limit condition will latch or unlatch for each RTD; reset used to unlatch.	Latch, unlatch
SysLim1 Type	Limit occurs when the temperature is greater than or equal (>=), or less than or equal to (<=) a preset value.	Greater than or equal Less than or equal
System Limit 1	Enter the desired value of the limit temperature, Deg F or Ohms	-60 to 1,300

	SysLim2 Enable	Enables or disables a temperature limit which can be used to create an alarm	Enable, disable
	SysLim2 Latch	Determines whether the limit condition will latch or unlatch; reset used to unlatch.	Latch, unlatch
	SysLim2 Type	Limit occurs when the temperature is greater than or equal (\geq), or less than or equal to (\leq) a preset value.	Greater than or equal Less than or equal
Limit 2	System	Enter the desired value of the limit temperature, Deg F or Ohms	-60 to 1,300
Diff Limt	TMR	Limit condition occurs if 3 temperatures in R,S,T differ by more than a preset value; this creates a voting alarm condition.	-60 to 1,300

Signals	Board Point	Description-Point Edit (Enter Signal Connection)	Direction	Type
	L3DIAG_VRTD1	Board diagnostic	Input	BIT
	L3DIAG_VRTD2	Board diagnostic	Input	BIT
	L3DIAG_VRTD3	Board diagnostic	Input	BIT
	SysLim1RTD1	System limit 1	Input	BIT
	:	:	Input	BIT
	SysLim1RTD16	System limit 1	Input	BIT
	SysLim2RTD1	System limit 2	Input	BIT
	:	:	Input	BIT
	SysLim2RTD16	System limit 2	Input	BIT